

**DATI DI TARGA - RATING PLATE - PLAQUE DU CONSTRUCTEUR - KENNDATEN - DATOS DE LA PLACA - PLACA DE IDENTIFICAÇÃO - ДАННЫЕ НА ЗАВОДСКОЙ ТАБЛИЧКЕ**

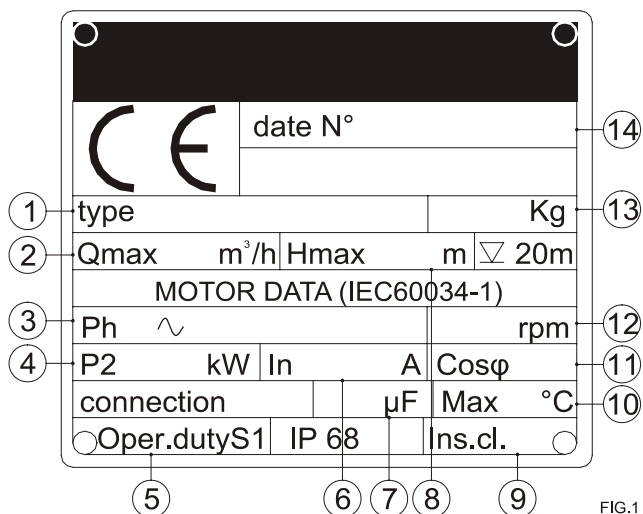
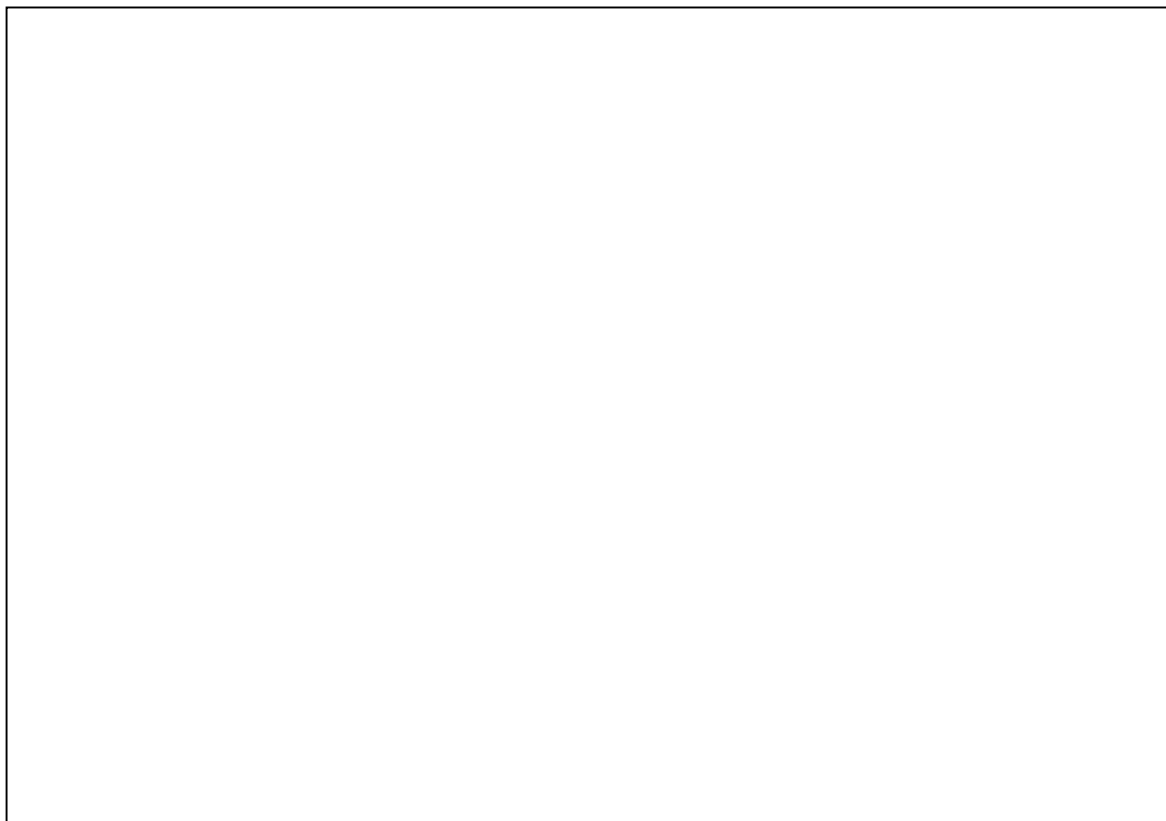





FIG.1

- 1) Tipo di pompa - pump type - type de pompe - Pumpentyp - tipo de bomba - tipo de bomba - Тип насоса
- 2) Portata massima - Max. delivery - débit max. - Max Fördermenge - capacidad maxima - capacidade máx - Общий расход
- 3) N° di fasi, tensione nominale, frequenza - n° of phases, rated voltage, frequency - n° de phases, tension nominale, fréquence - Stufenanzahl, Nennspannung, Frequenz - nro. de fases, tensión nominal, frecuencia - n° de fases, tensão nominal, frequência - Количество фаз, Номинальное напряжение, Частота.
- 4) Potenza nominale - rated power - puissance nominale - Nennleistung - potencia nominal - potência nominal - Номинальная мощность.
- 5) Fattore di servizio - operation Duty - facteur de fonctionnement - Betriebsfaktor - factor de servicio - factor de serviço - Коэффициент использования
- 6) Corrente nominale motore - Nom. motor current - courant nom. moteur - Stromaufnahme - corriente nom. motor - corriente nom. motor - Номинальная сила тока.
- 7) Capacità condensatore - capacitor rating - capacité condensateur - Kapazität des Kondensators - capacidad condensador - capacidade do consensador - Емкость конденсатора
- 8) Prevalenza massima - Max. head - hauteur de refoulement max. - Max. Förderhöhe - altura maxima - prevalência max - Общий напор
- 9) Classe isolamento - insulation class - classe isolation - isolierklasse - clase de aislamiento - classe isolamento - Класс изоляции.
- 10) Temperatura massima del liquido - Max. liquid temperature - temp.max du liquide - max. Flüssigkeitstemperatur - temp.máx del líquido - temp.máx do líquido - Максимальная жидкости температура
- 11) Fattore di potenza - power factor - fac. puissance - Leistungsfaktor factor de potencia - factor de potência - фактор силы
- 12) Velocità di rotazione - rotation speed rpm - vitesse de rotation - nenndrhzahl - velocidad de rotación - velocidade de rotação - Скорость вращения.
- 13) Peso - weight - poids - Gewicht - peso - peso - Вес
- 14) N° di matricola - serial number - n° d'immatriculation - Seriennummer - n° de serie - n°de matrícula - Паспортный №.



## SAFETY WARNINGS FOR PERSONS AND EQUIPMENT

These symbols    together with relative words: “Danger” and “Warning”, indicate the potential risk deriving from failure to observe the safety precautions to which they have been associated, as specified below.



**Danger**  
Risk of electric shock

Warns that failure to comply with the safety precautions may result in electric shock.



**Danger**

Warns that failure to comply with the safety precaution may result in damage to person and/or equipment.



**Warning**

Warns that failure to comply with the safety precautions may result in damage to the pump or the plant.

## HANDLING



**Warning**

Use the special lifting eyebolt on the head of the pump for the handling of the unpacked unit.



**Danger**  
Risk of electric shock

Do not use the electrical cable to lift the pump.

## WORKING LIMITS



**Warning**

- Maximum temperature of pumped liquid **40 °C**.

- The density of the pumped liquid must not exceed **1200 Kg/m<sup>3</sup>**.

- The size of suspended solids present in the pumped liquid must not exceed the free passage through the impeller.

- Minimum liquid level: the pump may work continuously at full load as long as the liquid level does not drop below the midpoint of the stator housing.

With cooling jacket: the pump may work continuously at full load, with dry installation, or with diffuser completely submerged.

- Immersion depth: maximum 20m.

- The electric pumps cannot be used for heads below the lowest point in the characteristic curve show in the catalogue. Lower heads result in the motor overload.



**Danger**

The electric pumps must not be used in environments where there is a risk of explosions, or for the pumping of flammable liquids.

## NOISE

Not applicable because the pump works submerged in wells.

By dry version: inferior to 70 db(A).

## APPLICATIONS

This series of submersible pumps has been designed for the pumping of waste water in industrial and civil installations, pumping of mud and of light agricultural sewage.

They are available in the following versions:

- **with lowering device:** the electric pump unit connects automatically with the coupling foot, which is fitted with two guide tubes to assist the lowering inside the pit;
- **with support foot:** coupling for flexible tube, handle and supporting foot.

## INSTALLATION

### SAFETY REGULATIONS

To avoid the risk of accidents during pump maintenance or installation, the following regulations should be observed:



**Danger**

- Never work alone. Use safety belt and rope and also a gas mask, if necessary. Do not overlook the risk of drowning.

- Make sure that sufficient oxygen is available and toxic fumes are present.

- Before welding or using electrical equipment make sure there are no risks of explosion.

- Do not overlook dangers to your health; follow common hygienic practices.

- Be aware of risks resulting from electrical malfunctions.

- Make sure that the hoisting equipment is in good condition.

- Install a suitable barrier around the working area.

- Make sure that a fast easy exit to the open air is available.

- Use a helmet, safety goggles and protective shoes.

- All the people working in sewage water pumping stations must be vaccinated against any diseases that may be transmitted.

- Never introduce your fingers inside the suction opening as there is a risk of injuries due to contact with the

impeller. Keep in mind that the pump may stop and restart automatically following the triggering of thermal protections or of remote control devices; only the power supply switch may eliminate this risk.

The pump has been designed to be used with liquids that may be hazardous to your health. To avoid injuries to your eyes or skin, comply with the following safety precautions when operating on the pump:

- always use safety goggles and rubber gloves;
- rinse the pump well with a hot water cleaning machine before servicing it;
- rinse the different components with clean water after having disassembled them;
- wrap a rag around the oil chamber screw whenever you have to loosen it, to prevent sprays from reaching your skin or eyes in the event that pressure has built up in the pump due to infiltration of the pumped liquid.

In the event of contact with toxic chemicals, proceed as follows:

- eyes: Rinse immediately with running water for 15 minutes keeping eyelids wide open. Contact an eye doctor;
- skin: Remove the contaminated clothing, wash skin with soap and water; if necessary, consult a doctor.

**FOLLOW ALL THE OTHER HYGIENIC AND SAFETY PRACTICES AND LOCAL RULES AND REGULATIONS.**

**HOISTING EQUIPMENT**

Suitable hoisting equipment is necessary for lifting the pump and lowering it inside the well, if possible without requiring a take-up.

The minimum distance between the lifting hook and the trap/floor must be 0.8m to allow for the extraction of the pump from the well.

Oversized hoisting equipment may cause damage to the pump in the event that it should get jammed during the lifting operations. Make sure that the lifting equipment is properly secured.



**Danger**

WARNING! Keep clear of suspended loads.

**ELECTRICAL CONNECTIONS**

The entire electric system must be installed by skilled personnel. Follow local rules and regulations.



**Danger**

Risk of electric shock

If the cable must be replaced, for safety reasons, the earth conductor (yellow-green) must be about 50 mm longer than the phase conductors. In the event that the cable should accidentally come loose, the earth

terminal must be the last one to be disconnected.

The command and control equipment cannot be installed inside the sump pit.

Remember that the initial input current for direct starting may be up to 6 times the rated absorption; therefore, make sure that the fuses or the automatic switches have the adequate setting.



**Warning**

- Any splicing of the supply cable must be absolutely water proof.
- Make sure that the mains voltage and frequency correspond with the pump rating.
- The supply voltage must agree with the specifications indicated on the rating plate, with a 10% tolerance.
- Always check the current absorbed by the pump.
- Make sure that the setting of the temperature relay does not exceed the indicated value at page 3.

**ELECTRIC MOTOR**

Motor asynchronous three-phase squirrel cage type, insulation class H (180°C). Dry motor, cooled by surrounding liquid. Protection degree IP 68.

The motor is designed for continuous or intermittent operation, with a maximum of 15 starts per hour at regular intervals.

The motor is designed for work with 5% maximum voltage unbalance between the phases (in compliance with norms CEI EN 60034-1).

**DIRECTION OF ROTATION**

The direction of rotation must be carefully checked when the pumps are started.



**Warning**

**If the direction of rotation is wrong the delivery of the pump is inadequate and may result in damage to the unit.**

The direction of rotation is correct if, at starting, you notice an counter-clockwise recoil when looking at the pump from the cable gland side.

Three-phase: if the direction of rotation is wrong you need to invert any 2 of the 3 phase wires on the terminal board of the electrical box.



**Danger**

Risk of electric shock

**DO NOT USE THE ELECTRIC CABLE TO LIFT THE PUMP**

Take good care of the supply cable; replace it immediately if damaged.



**Warning**

WARNING! The end of the cable must not be submerged. The cable

terminals must be securely fastened above the maximum level of the liquid, to prevent the water from penetrating inside the motor through the cable.

## ELECTRICAL PANEL\*



**Danger**  
Risk of electric  
shock

**Do not connect the pump directly by means a plug; connect the electric cable to a control box with thermal protection.**

This series of submersible pumps must be equipped with an electrical control panel. The panel must be designed to allow both manual and automatic operation.

It should be equipped with at least a low voltage control circuit, an automatic level control and adjustment circuit, a circuit for detecting any operating anomalies.

The complete control panel can be supplied upon request.

\* not applicable for electric pumps equipped of plug.

## AUTOMATIC CONTROL

The automatic pump control is obtained by means of two automatic level regulators which utilize a single-contact switch (only on or off).

They are installed inside the sump fastened to the bracket which is secured to the edge of the sump cover (see page 41).

An automatic alternating system must be provided for in case more than one pump is installed in a single sump.

The intervention levels are adjusted by loosening the clamps of the fastening bracket and by lifting or lowering the supply cable. The pump activation regulator must be positioned at a lower level than the liquid supply pipe.

The shut-off regulator must be positioned so as to prevent the pump from sucking air.

An alarm system (flashing or siren) can be connected by means of another regulator (positioned approx. 10 cm. above the pump activation level).



**Warning**

The difference in level between the pump activation and shutdown must allow for a maximum of 15 starts per hour.

To ensure proper operation the regulators must float freely, be positioned away from the walls or any other obstruction; they must not come into contact with the bottom of the sump or be directly in the path of the liquid supply stream.

The level regulators must also be periodically inspected to eliminate any caking due to greasy substances or filaments which may impede normal operations.

## WATER INFILTRATION DETECTOR

For pump equipped with a built-in device that detects water infiltration in the oil chamber.

The sensor reveals the presence of water in the oil when it exceeds 30%. If the sensor is activated the oil should be changed.

In the event that the sensor is activated again after a short time since the oil was changed, we recommend the replacement of the mechanical seal (see oil change page 11).

## AUTOMATIC COUPLING WITH TWO DESCENT GUIDING TUBES

The automatic coupling system allows for quick and efficient inspection operations.

The coupling foot is fastened to the bottom of the sump together with the delivery pipe; two guiding tubes connect it to the anchoring bracket secured to the edge of the sump cover.

The pump is lowered along the guiding tubes until it reaches the exact coupling position; the seal will be tight thanks to the weight of the pump.

This operation can be repeated any number of times and it makes checking and inspection operations easier; the pump is simply extracted from the sump by means of a chain (even if the system is flooded), checked or repaired and reassembled.

## ASSEMBLY

1. Secure the upper bracket of the guiding tube to the center of the inner wall below the sump cover, on the side where the delivery pipe must be installed (see page 40).  
With the help of a plumb line make sure that the guiding tubes is vertical.
2. Position the coupling foot at the bottom of the sump in such a way that the tapered projection on which the guiding tube will fit is plumb and in line with the upper bracket.  
Mark the fastening holes for the expansion bolts, remove the foot and drill 4 holes, insert the bolts and rest the foot on them.  
Position the guiding tubes on the special tapered projection on the foot and determine its final length.
3. For wells that are more than 6 m deep, intermediate brackets are necessary for the joining of the guiding tubes.
4. Position the guiding tubes between the tapered projection of the foot and that of the upper bracket; again make sure that the tube is perfectly vertical.

5. Fasten the coupling foot using plain washers and nuts; insert the upper bracket inside the guiding tubes making sure that there is no verticals lack and fasten it.
6. Connect the delivery pipe to the coupling foot using a plain gasket and screws.
7. Insert the gasket inside the coupling counterflange. Fasten the counterflange to the pump delivery outlet with screws.
8. To lower the pump inside the sump secure the chain to the special eye bolt cast on the head of the unit.
9. Fit the coupling counter flange in the upper bracket and lower the pump inside the sump, letting it slide along the guiding tubes.  
When it reaches the bottom, the pump will automatically connect with the coupling foot.
10. Secure the chain and electrical cables to the upper bracket, fit the electrical cables inside the special guards between the well and the control panel.



**Warning** Make sure that the cables are not bent or pinched, to avoid undue wear or damage.

### CHECK AND MAINTENANCE



**Danger** WARNING! Never introduce your fingers inside the suction inlet as there is a risk of injuries due to contact with the impeller. Keep in mind that the pump may stop and restart automatically following the triggering of thermal protections or of remote control devices; only the interruption of the mains supply may eliminate this risk.

### INSPECTIONS

Periodical checks and preventive maintenance ensure safer operation for a longer period of time. The pump must be inspected after 2000 working hours or at least once a year and, in case of operations under particularly stressful conditions, the inspections must be more frequent. On these occasions remember to check the oil.

Under normal working conditions the pump should be overhauled by a qualified mechanic every three years.

### OIL CHANGE

The oil chamber is filled at the factory; if there are traces of water or light emulsion the oil has to be changed. The pump must be extracted from the sump. The oil plug is on the side of the oil chamber; we suggest performing this operation at a shop.



**Danger** - WARNING! If there is infiltration through the seal the oil chamber may be under pressure. To avoid sprays

wrap a rag around the oil tank screw when you loosen it.

- Loosen the oil chamber plug and let all the oil out, then refill using the prescribed quantity of lubricant (see page 3); tighten the plug, remembering that the copper washer must always be replaced.

- If you notice that the oil is emulsified or that there are evident signs of water, check the lower mechanical seal; replace it if necessary or contact an authorized dealer.

### CLEANING

For clean impeller from filamentous materials, it can be sufficient to start the pump for a few seconds, with opposite direction of rotation.

If the pump is used only occasionally it should be cleaned after each operation by flushing with clean water to eliminate deposits and caking.

We recommend you periodically check the condition of the automatic level switches, especially in fixed installations. By activating the selector switch (manual position) the tank or sump pit are emptied. If any dirt deposits are found on the float switch they must be removed.

After cleaning, the sump should be flushed with clean water. A few start and stop cycles, with the selector switch in automatic position, are recommended.

### CHECKING

If the pump works but the delivery is inadequate check the following:

- the direction of the pump rotation. See "Direction of rotation";
- make sure the valves are open and intact;
- make sure the tubes, impeller and filter are not obstructed;
- the impeller should rotate freely;
- make sure that the head required by the plant has not changed;
- check for leaks in the pipes;
- make sure the impeller is not worn.



**Warning** Do not continuously try to start the mixer if the thermal protection device triggers.

**SCHEMA DEI COLLEGAMENTI ELETTRICI MONOFASE**  
**ELECTRICAL CONNECTION DIAGRAM SINGLE PHASE**  
**SCHÉMA DES BRANCHEMENTS ÉLECTRIQUES MONOPHASÉE**  
**SCHEMA DER ELEKTRISCHEN ANSCHLÜSSE WECHSELSTR**  
**DIAGRAMA DE LAS CONEXIONES ELÉCTRICAS MONOFÁSICAS**  
**ESQUEMAS DAS LIGAÇÕES ELÉCTRICAS MONOFÁSICAS**  
**ЭЛЕКТРИЧЕСКАЯ СХЕМА (МОНОФАЗНЫЙ ВАРИАНТ)**

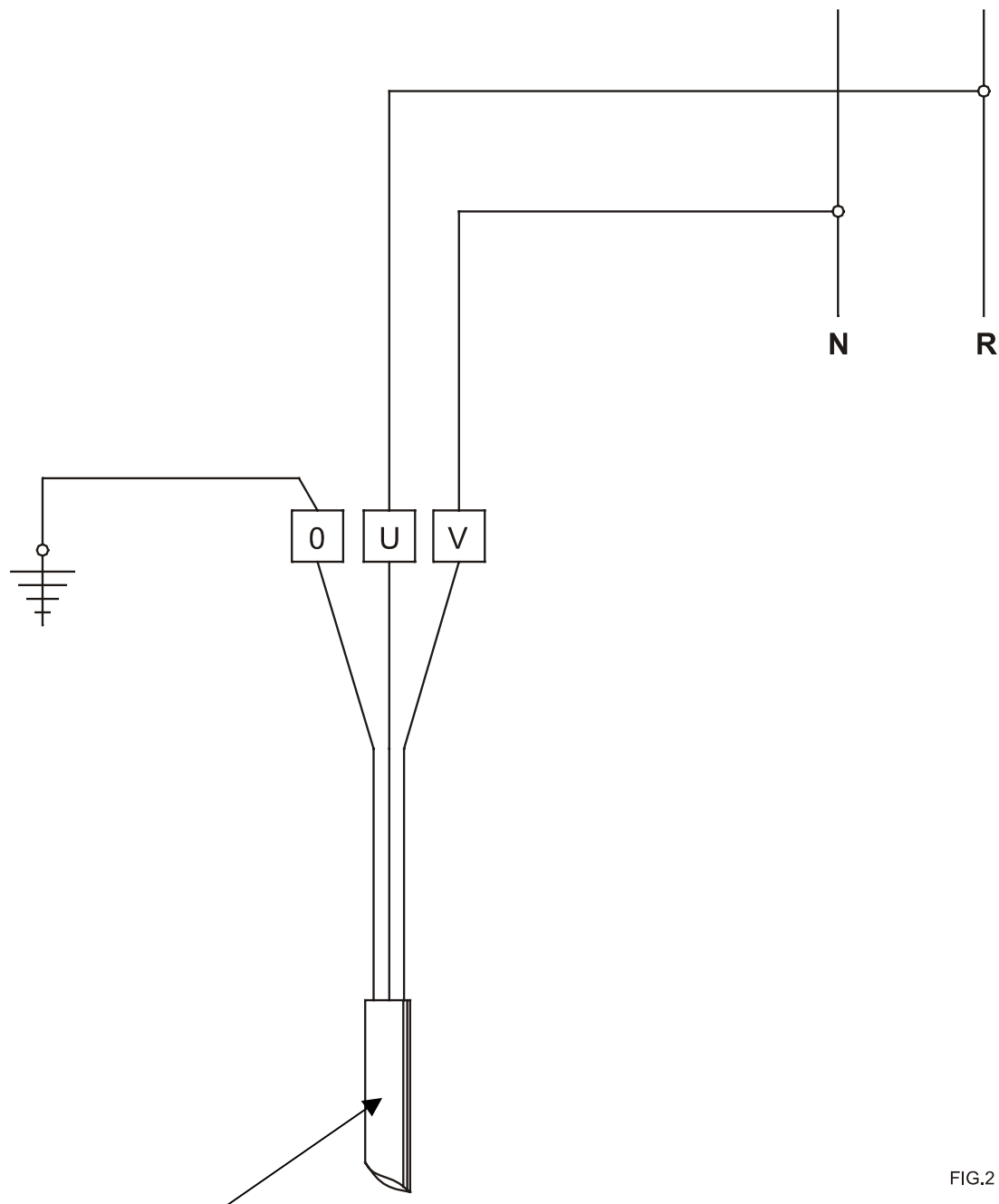

FIG.2

Cavo a 3 conduttori dell'elettropompa - 3 lead electric pump cable - câble de l'électropompe, a 3 conducteurs - 3 leiter-kabel - cable a 3 conductores de la electrobomba - cabo de 3 conductores da electrobomba - 3-жильный кабель электронасоса.

**U** = RETE: COLORE MARRONE - MAINS: COLOUR BROWN - SECTEUR: COULEUR MARRON - NETZ: FARBE BROWN - RED: COLOR MARRÓN - REDE: COR CASTANHA - СЕТЬ: КОРИЧНЕВАЯ ЖИЛА.

**V** = RETE: COLORE BLU - MAINS: COLOUR BLUE - SECTEUR: COULEUR BLEU - NETZ: FARBE BLAU - RED: COLOR AZUL - REDE: COR AZUL - СЕТЬ: СИНЯЯ ЖИЛА.

**0** = MASSA/TERRA - EARTH/GROUND - MASSE/TERRER - MASSE/ERDE - MASA / TIERRA - MASSA/TERRA - МАССА/ЗАЗЕМЛЕНИЕ

**SCHEMA DEI COLLEGAMENTI ELETTRICI MONOFASE  
ELECTRICAL CONNECTION DIAGRAM SINGLE PHASE  
SCHÉMA DES BRANCHEMENTS ÉLECTRIQUES MONOPHASÉE  
SCHEMA DER ELEKTRISCHEN ANSCHLÜSSE WECHSELSTR  
DIAGRAMA DE LAS CONEXIONES ELÉCTRICAS MONOFÁSICAS  
ESQUEMAS DAS LIGAÇÕES ELÉCTRICAS MONOFÁSICAS  
ЭЛЕКТРИЧЕСКАЯ СХЕМА (МОНОФАЗНЫЙ ВАРИАНТ)**

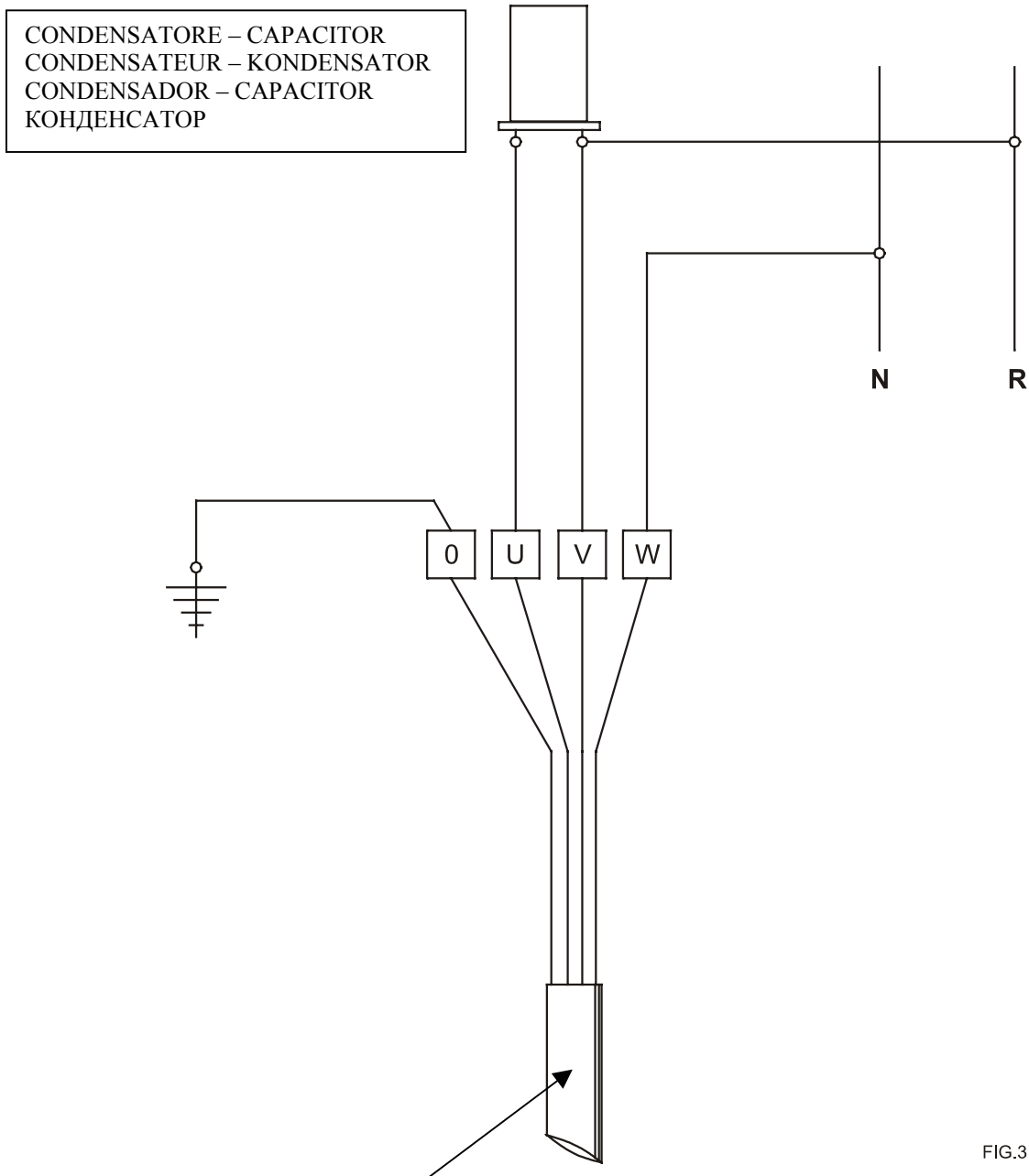

FIG.3

Cavo a 4 conduttori dell'elettropompa - 4 lead electric pump cable - câble de l'électropompe, a 4 conducteurs - 4 leiter-kabel - cable a 4 conductores de la electrobomba - cabo de 4 condutores da electrobomba - 4-жильный кабель электронасоса.

- W** = RETE: COLORE NERO - MAINS: COLOUR BLACK - SECTEUR: COULEUR NOIR - NETZ: FARBE SCHWARZ - RED: COLOR NEGRO - REDE: COR PRETA - СЕТЬ: ЧЕРНАЯ ЖИЛА
- V** = CONDENSATORE + RETE: COLORE BLU - CAPACITOR + MAINS: COLOUR BLUE - CONDENSATEUR + SECTEUR: COULEUR BLEU - KONDENSATOR + NETZ: FARBE BLAU - CONDENSADOR + RED: COLOR AZUL - CONDENSADOR + REDE: COR AZUL - КОНДЕНСАТОР + СЕТЬ: СИНЯЯ ЖИЛА
- U** = CONDENSATORE: COLORE MARRONE - CAPACITOR: COLOUR BROWN - CONDENSATEUR: COULEUR MARRON - KONDENSATOR: FARBE BROWN - CONDENSADOR COLOR MARRÓN - CONDENSADOR: COR CASTANHA - КОНДЕНСАТОР: КОРИЧНЕВАЯ ЖИЛА
- 0** = MASSA/TERRA - EARTH/GROUND - MASSE/TERRE - MASSE/ERDE - MASA / TIERRA - MASSA/TERRA - МАССА/ЗАЕМЛЕНИЕ

SCHEMA DEI COLLEGAMENTI ELETTRICI COLLEGAMENTO DIRETTO  
 ELECTRICAL CONNECTION DIAGRAM DIRECT CONNECTION  
 SCHÉMA DES BRANCHEMENTS ÉLECTRIQUES BRANCHEMENT DIRECT  
 SCHEMA DER ELEKTRISCHEN ANSCHLÜSSE  
 DIAGRAMA DE LAS CONEXIONES ELÉCTRICAS CONEXIÓN DIRECTA  
 ESQUEMA DAS LIGAÇÕES ELÉCTRICA LIGAÇÃO DIRETA  
 ЭЛЕКТРИЧЕСКАЯ СХЕМА ДЛЯ ПРЯМОГО СОЕДИНЕНИЯ

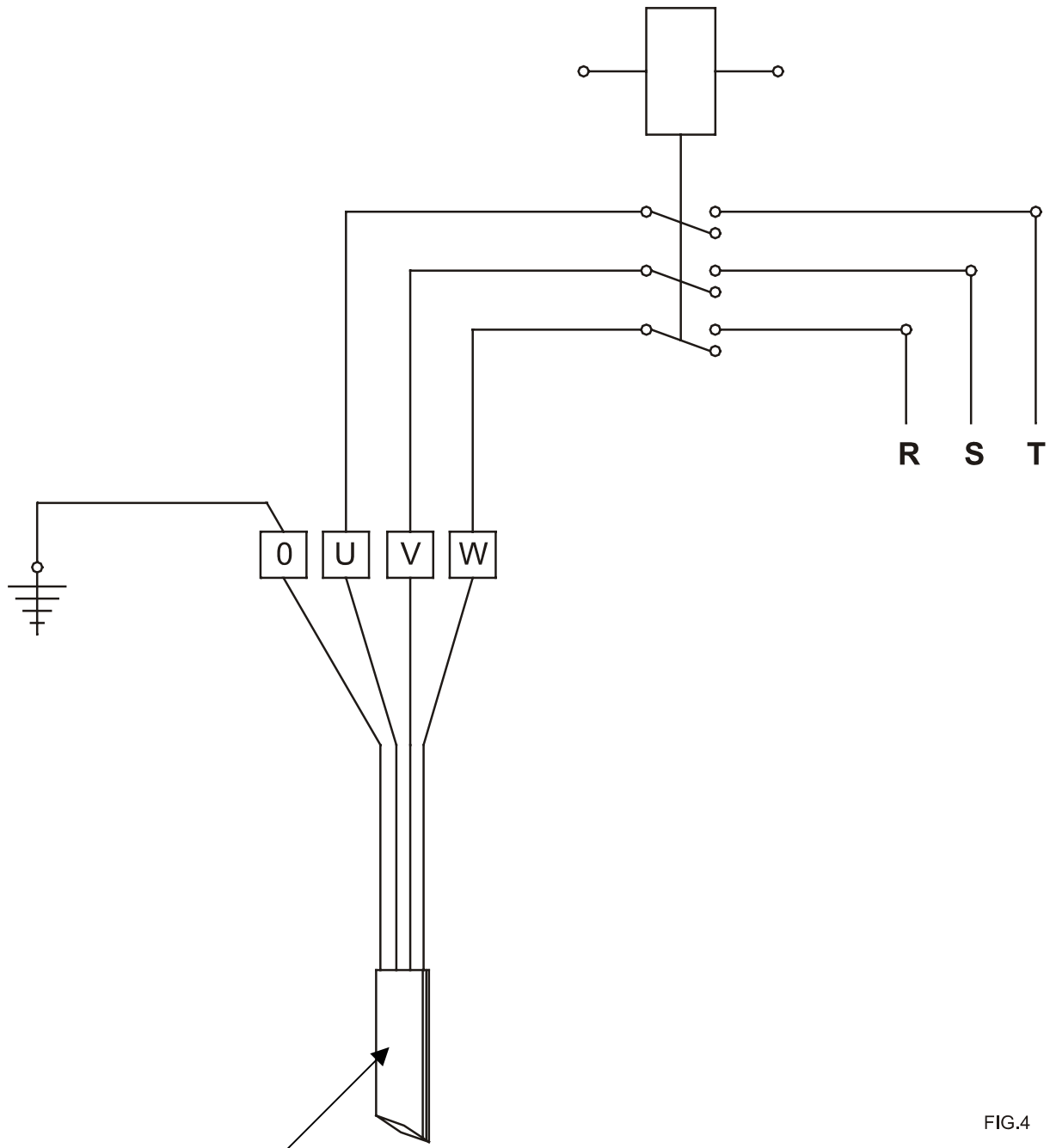

FIG.4

Cavo a 4 conduttori dell'elettropompa - 4 lead electric pump cable - câble de l'électropompe, a 4 conducteurs - 4 leiter-kabel - cable a 4 conductores de la electrobomba - cabo de 4 conductores da electrobomba - 4-жильный кабель электронасоса

- W** = RETE: COLORE NERO - MAINS: COLOUR BLACK - SECTEUR: COULEUR NOIR - NETZ: FARBE SCHWARZ - RED: COLOR NEGRO - REDE: COR PRETA - СЕТЬ: ЧЕРНАЯ ЖИЛА
- V** = RETE: COLORE GRIGIO - MAINS: COLOUR GRAY - SECTEUR: COULEUR GRIS - NETZ: FARBE GRAU - RED: COLOR GRIS - REDE: COR CINZENTO - СЕТЬ: СЕРЫЙ ЖИЛА
- U** = RETE: COLORE MARRONE - MAINS: COLOUR BROWN - SECTEUR: COULEUR MARRON - NETZ: FARBE BROWN - RED: COLOR MARRÓN - REDE: COR CASTANHA - СЕТЬ: КОРИЧНЕВАЯ ЖИЛА
- 0** = MASSA/TERRA - EARTH/GROUND - MASSE/TERRE - MASSE/ERDE - MASA / TIERRA - MASSA/TERRA - МАССА/ЗАЕМЛЕНИЕ.



**SCHEMA DEI COLLEGAMENTI ELETTRICI COLLEGAMENTO DIRETTO  
ELECTRICAL CONNECTION DIAGRAM DIRECT CONNECTION  
SCHÉMA DES BRANCHEMENTS ÉLECTRIQUES BRANCHEMENT DIRECT  
SCHEMA DER ELEKTRISCHEN ANSCHLÜSSE  
DIAGRAMA DE LAS CONEXIONES ELÉCTRICAS CONEXIÓN DIRECTA  
ESQUEMA DAS LIGAÇÕES ELÉCTRICA LIGAÇÃO DIRETA  
ЭЛЕКТРИЧЕСКАЯ СХЕМА ДЛЯ ПРЯМОГО СОЕДИНЕНИЯ**

Da collegare al morsetto del rivelatore acqua solo se l'elettropompa è fornita dell'apposito quadro di controllo.  
To be connected to the water-probe only if the pump is equipped with specific control panel.  
A connecter à la borne du détecteur eau seulement si l'électropompe est munie du coffret de commande.  
Der Anschluß an die Klemme der Feuchtigkeitssonde ist nur dann vorzunehmen, wenn die Motorpumpe mit der entsprechenden Schalttafel geliefert wird.  
A conectar al borne do revelador água solo si a electrobomba dispone del respectivo cuadro de control.  
A ligar ao borne do detector de água só se a electrobomba é fornecida com o respectivo quadro de controle.  
Подсоединяется к клемме датчика воды при условии, что электронасос имеет соответствующий пульт управления.

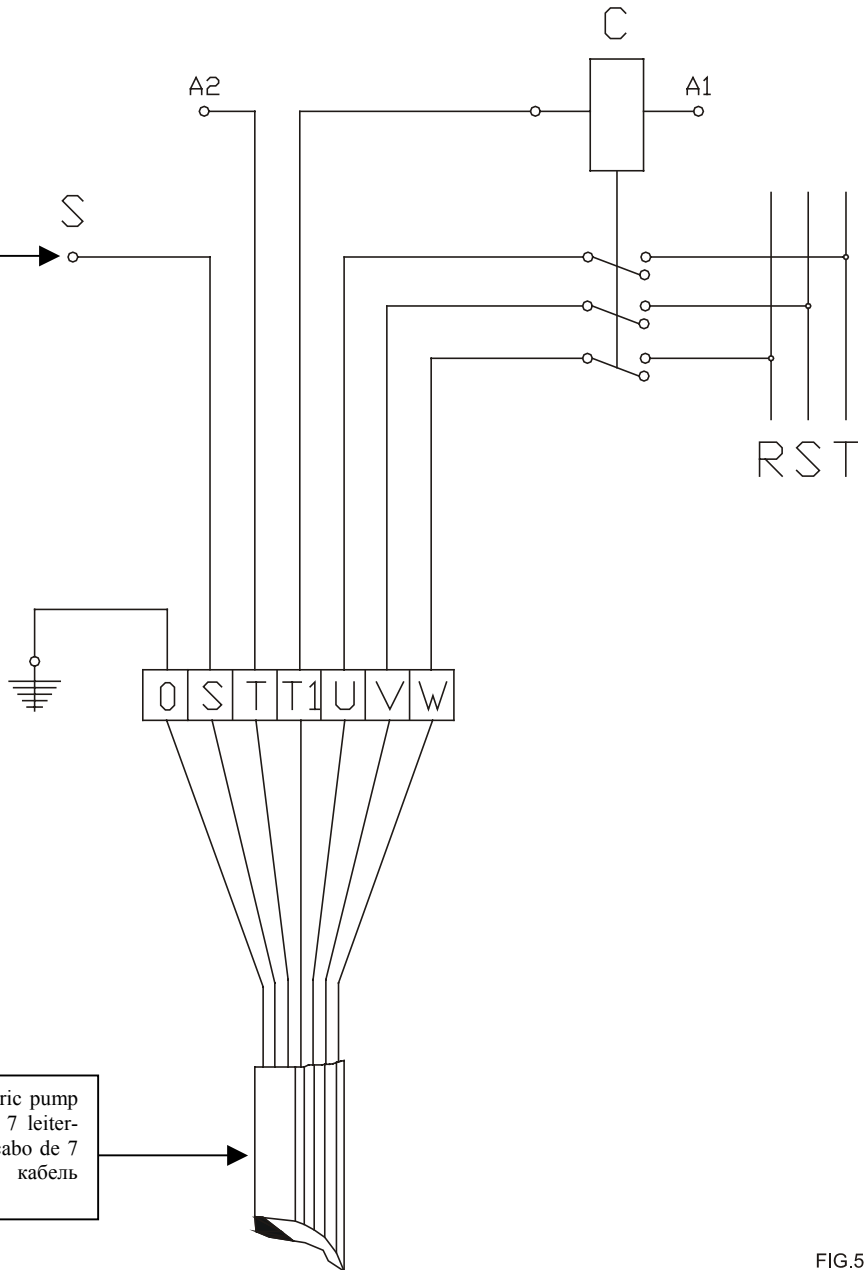

Cavo a 7 conduttori dell'elettropompa - 7 lead electric pump cable - câble de l'électropompe, a 7 conducteurs - 7 leiterkabel - cable a 7 conductores de la electrobomba - cabo de 7 condutores da electrobomba - 7-жильный кабель электронасоса

- U(4) - V(5) - W(6)** = RETE - MAINS - SECTEUR - NETZ - RED - REDE - СЕТЬ
- T(1) - T1(2)** = PROTETTORI TERMICI - THERMAL PROBE - PROTECTIONS THERMIQUES - THERMOSCHUTZVORRICHTUNGEN - PROTECTORES TÉRMICOS - PROTECTORES TÉRMICOS - ТЕПЛОЗАЩИТНЫЕ ПРИСПОСОБЛЕНИЯ
- S(3)** = SONDA RILEV. ACQUA OPZIONALE - HUMIDITY PROBE OPTION - SONDE DE PRÉSENCE D'EAU OPTION - SENSOR - SONDA DETEC. AGUA OPCIONAL - SONDA DETECTORA DE ÁGUA OPCIONAL - ДАТЧИК ОПРЕДЕЛЕНИЯ ВОДЫ (ОПЦИЯ)

FIG.5

Apparecchiatura per rilevamento presenza acqua nella camera olio.  
Equipment for reveal presence of water in the oil chamber.  
Équipement pour relevé présence eau dans la chambre d'huile.  
Ausrüstung für decken Vorhandensein des Wassers im Ölraum auf  
Equipamiento para relación presencia agua en la cámara de aceite.  
O equipamento para revela a presença da água na câmara do óleo  
Электрод для контроля присутствия воды в масляной камере

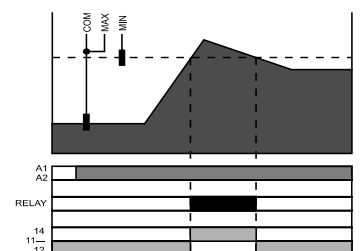
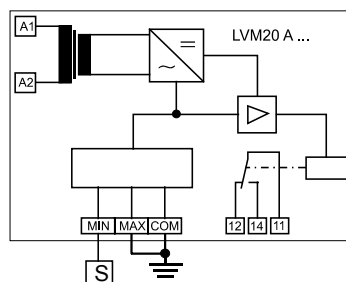

**SCHEMA DEI COLLEGAMENTI ELETTRICI COLLEGAMENTO DIRETTO  
ELECTRICAL CONNECTION DIAGRAM DIRECT CONNECTION  
SCHÉMA DES BRANCHEMENTS ÉLECTRIQUES BRANCHEMENT DIRECT  
SCHEMA DER ELEKTRISCHEN ANSCHLÜSSE  
DIAGRAMA DE LAS CONEXIONES ELÉCTRICAS CONEXIÓN DIRECTA  
ESQUEMA DAS LIGAÇÕES ELÉCTRICA LIGAÇÃO DIRETA  
ЭЛЕКТРИЧЕСКАЯ СХЕМА ДЛЯ ПРЯМОГО СОЕДИНЕНИЯ**

Da collegare al morsetto del rivelatore acqua solo se l'elettropompa è fornita dell'apposito quadro di controllo.  
To be connected to the water-probe only if the pump is equipped with specific control panel.  
A connecter à la borne du détecteur eau seulement si l'électropompe est munie du coffret de commande.  
Der Anschluß an die Klemme der Feuchtigkeitssonde ist nur dann vorzunehmen, wenn die Motorpumpe mit der entsprechenden Schalttafel geliefert wird.  
A conectar al borne del revelador agua solo si la electrobomba dispone del respectivo cuadro de control.  
A ligar ao borne do detector de água só se a electrobomba é fornecida com o respectivo quadro de controle.  
Подсоединяется к клемме датчика воды при условии, что электронасос имеет соответствующий пульт управления.

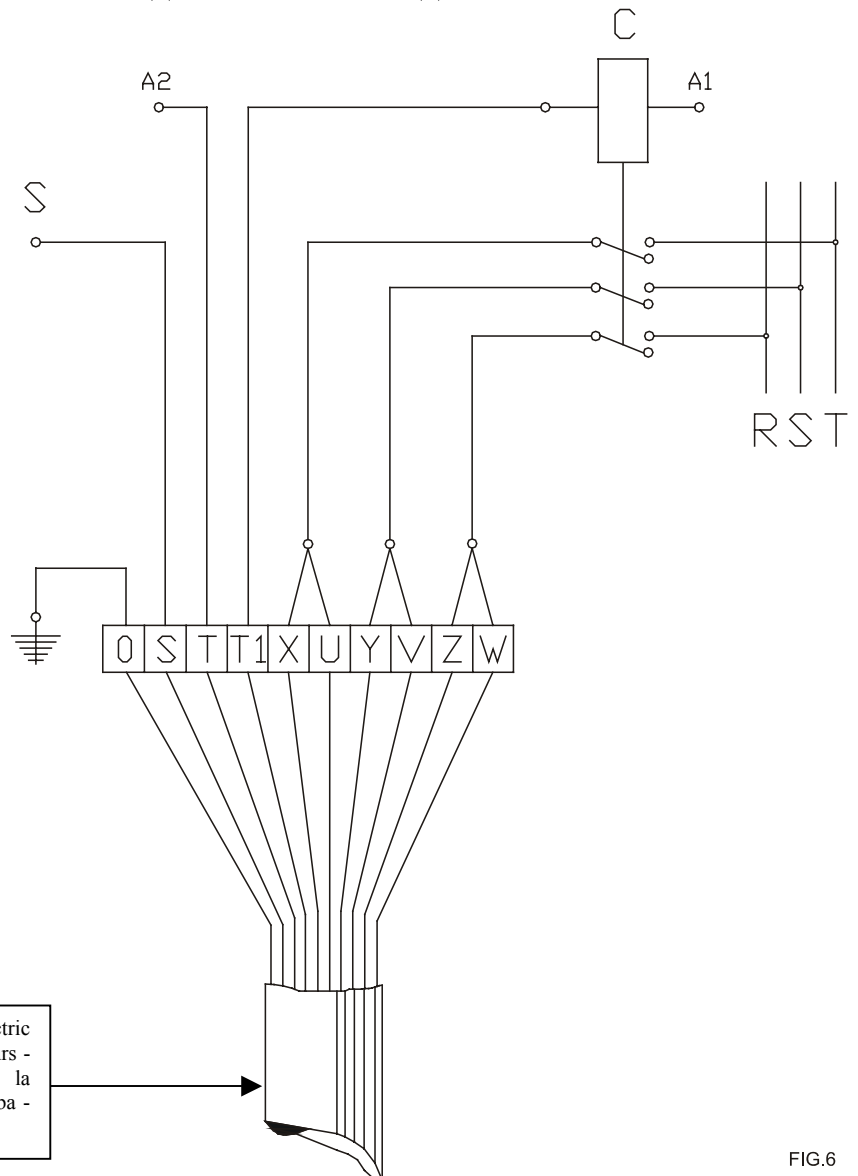

Cavo a 10 conduttori dell'elettropompa - 10 lead electric pump cable - câble de l'électropompe, a 10 conducteurs - 10 leiter-kabel - cable a 10 conductores de la electrobomba - cabo de 10 conductores da electrobomba - 10-жильный кабель электронасоса

FIG.6

- X(7) - U(4)** = RETE - MAINS - SECTEUR - NETZ - RED - REDE - СЕТЬ
- Y(8) - V(5)** = RETE - MAINS - SECTEUR - NETZ - RED - REDE - СЕТЬ
- Z(9) - W(6)** = RETE - MAINS - SECTEUR - NETZ - RED - REDE - СЕТЬ
- T(1) - T1(2)** = PROTETTORI TERMICI - THERMAL PROBE - PROTECTIONS THERMIQUES - THERMOSCHUTZVORRICHTUNGEN - PROTECTORES TÉRMICOS - PROTECTORES TÉRMICOS - ТЕПЛОЗАЩИТНЫЕ ПРИСПОСОБЛЕНИЯ
- S(3)** = SONDA RILEV. ACQUA - HUMIDITY PROBE - SONDE DE PRÉSENCE D'EAU - SENSOR - SONDA DETEC. AGUA - SONDA DETECTORA DE ÁGUA - ДАТЧИК ОПРЕДЕЛЕНИЯ ВОДЫ (ОПЦИЯ)

Apparecchiatura per rilevamento presenza acqua nella camera olio.  
Equipment for reveal presence of water in the oil chamber.  
Équipement pour relevé présence eau dans la chambre d'huile.  
Ausrüstung für decken Vorhandensein des Wassers im Ölraum auf  
Equipamiento para relación presencia agua en la cámara de aceite.  
O equipamento para revela a presença da água na câmara do óleo  
Электрод для контроля присутствия воды в масляной камере

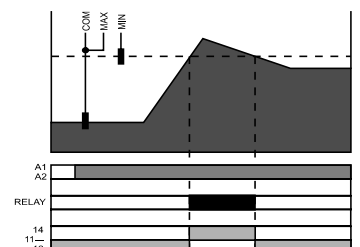
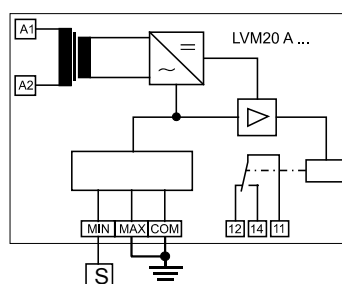

**SCHEMA DEI COLLEGAMENTI ELETTRICI COLLEGAMENTO STELLA/TRIANGOLO  
ELECTRICAL CONNECTION DIAGRAM STAR/DELTA CONNECTION  
SCHÉMA DES BRANCHEMENTS ÉLECTRIQUES CONNEXION ÉTOILE/TRIANGLE  
SCHEMA DER ELEKTRISCHEN ANSCHLÜSSE STERN-DREIECK ANSCHLUB  
DIAGRAMA DE LAS CONEXIONES ELÉCTRICAS CONEXIÓN ESTRELLA/TRIÁNGULO  
ESQUEMA DAS LIGAÇÕES ELÉCTRICAS LIGAÇÃO ESTRELA/TRIÂNGULO  
ЭЛЕКТРИЧЕСКАЯ СХЕМА ДЛЯ СОЕДИНЕНИЯ ЗВЕЗДА/ТРЕУГОЛЬНИК**

Da collegare al morsetto del rivelatore acqua solo se l'elettropompa è fornita dell'apposito quadro di controllo.  
To be connected to the water-probe only if the pump is equipped with specific control panel.  
A connecter à la borne du détecteur eau seulement si l'électropompe est munie du coffret de commande.  
Der Anschluß an die Klemme der Feuchtigkeitssonde ist nur dann vorzunehmen, wenn die Motorpumpe mit der entsprechenden Schalttafel geliefert wird.  
A conectar al borne del revelador agua solo si la electrobomba dispone del respectivo cuadro de control.  
A ligar ao borne do detector de água só se a electobomba é fornecida com o respectivo quadro de controle.  
Подсоединяется к клемме датчика воды при условии, что электронасос имеет соответствующий пульт управления.

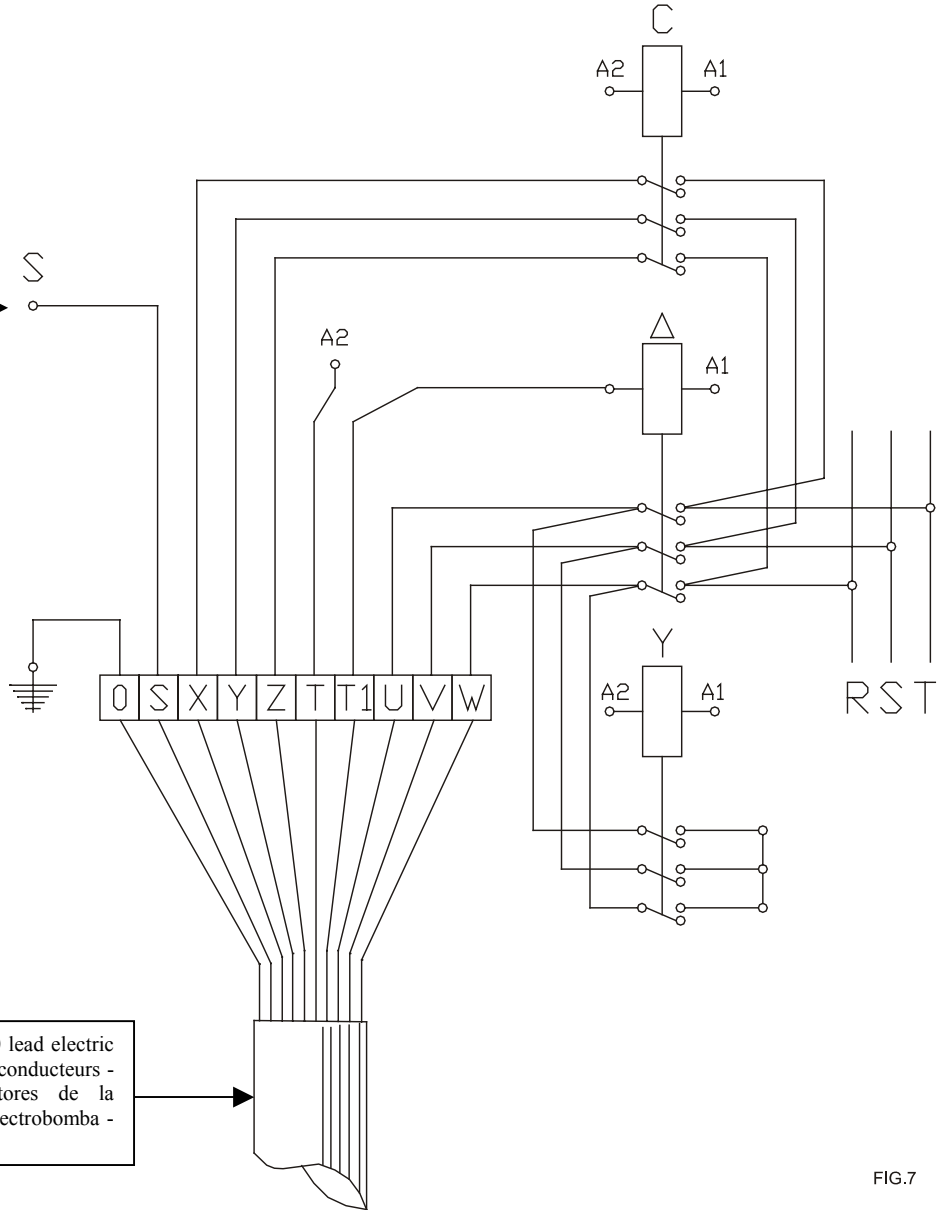

Cavo a 10 conduttori dell'elettropompa - 10 lead electric pump cable - câble de l'électropompe, a 10 conducteurs - 10 leiter-kabel - cable a 10 conductores de la electrobomba - cabo de 10 condutores da electobomba - 10-жильный кабель электронасоса

FIG.7

- X(7) - Y(8) - Z(9)** = RETE - MAINS - SECTEUR - NETZ - RED - REDE - СЕТЬ  
**U(4) - V(5) - W(6)** = RETE - MAINS - SECTEUR - NETZ - RED - REDE - СЕТЬ  
**T(1) - T1(2)** = PROTETTORI TERMICI - THERMAL PROBE - PROTECTIONS THERMIQUES - THERMOSCHUTZVORRICHTUNGEN - PROTECTORES TÉRMICOS - PROTECTORES TÉRMICOS - ТЕПЛОЗАЩИТНЫЕ ПРИСПОСОБЛЕНИЯ  
**S(3)** = SONDA RILEV. ACQUA - HUMIDITY PROBE - SONDE DE PRÉSENCE D'EAU - SENSOR - SONDA DETEC. AGUA - SONDA DETECTORA DE ÁGUA - ДАТЧИК ОПРЕДЕЛЕНИЯ ВОДЫ (ОПЦИЯ)

Apparecchiatura per rilevamento presenza acqua nella camera olio.  
Equipment for reveal presence of water in the oil chamber.  
Équipement pour relevé présence eau dans la chambre d'huile.  
Ausrüstung für decken Vorhandensein des Wassers im Ölraum auf  
Equipamiento para relación presencia agua en la cámara de aceite.  
O equipamento para revela a presença da água na câmara do óleo  
Электрод для контроля присутствия воды в масляной камере

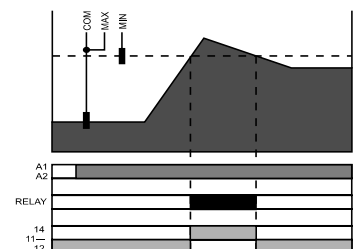
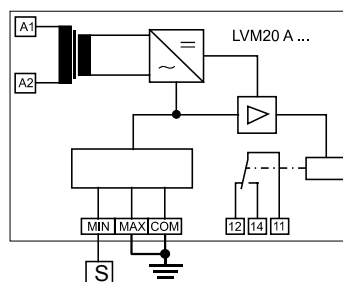

**SCHEMA DEI COLLEGAMENTI ELETTRICI COLLEGAMENTO DIRETTO  
ELECTRICAL CONNECTION DIAGRAM DIRECT CONNECTION  
SCHÉMA DES BRANCHEMENTS ÉLECTRIQUES BRANCHEMENT DIRECT  
SCHEMA DER ELEKTRISCHEN ANSCHLÜSSE  
DIAGRAMA DE LAS CONEXIONES ELÉCTRICAS CONEXIÓN DIRECTA  
ESQUEMA DAS LIGAÇÕES ELÉCTRICA LIGAÇÃO DIRETA  
ЭЛЕКТРИЧЕСКАЯ СХЕМА ДЛЯ ПРЯМОГО СОЕДИНЕНИЯ**

Da collegare al morsetto del rivelatore acqua solo se l'elettropompa è fornita dell'apposito quadro di controllo.  
To be connected to the water-probe only if the pump is equipped with specific control panel.  
A connecter à la borne du détecteur eau seulement si l'électropompe est munie du coffret de commande.  
Der Anschluß an die Klemme der Feuchtigkeitssonde ist nur dann vorzunehmen, wenn die Motorpumpe mit der entsprechenden Schalttafel geliefert wird.  
A conectar al borne del revelador agua solo si la electrobomba dispone del respectivo cuadro de control.  
A ligar ao borne do detector de água só se a electrobomba é fomecida com o respectivo quadro de controle.  
Подсоединяется к клемме датчика воды при условии, что электронасос имеет соответствующий пульт управления.

Cavi a 4 conduttori dell'elettropompa - 4 lead electric pump cables - câbles de l'électropompe, a 4 conducteurs - 4 leiter-kabel - cables a 4 conductores de la electrobomba - cabos de 4 conductores da electrobomba - 4-жильный кабель электронасоса

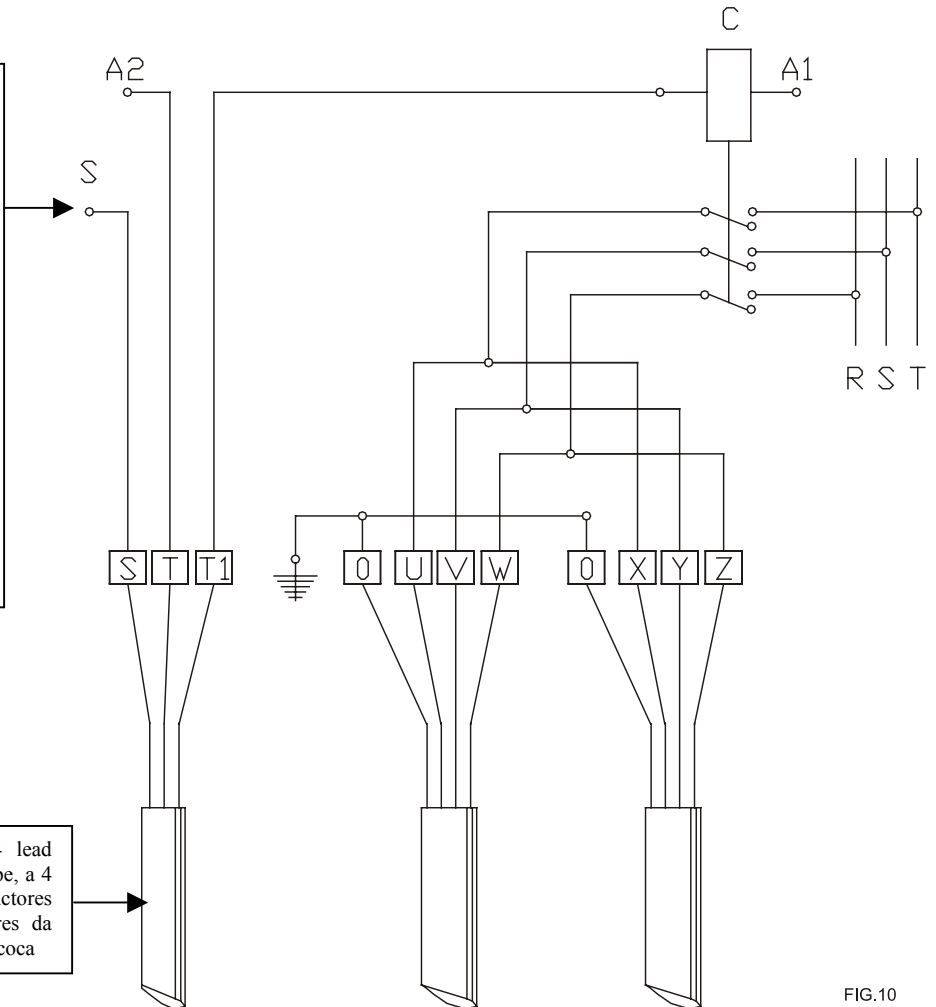
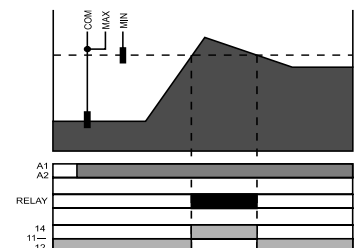
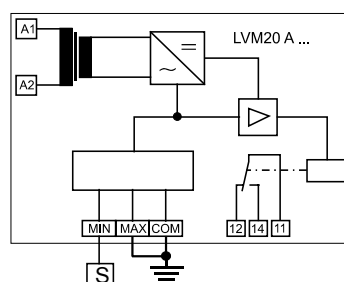

FIG.10

- X - U** = RETE: GRIGIO E NERO - MAINS: GRAY AND BLACK – SECTEUR: GRIS ET NOIR – NETZ: GRAU UND SCHWARZ – RED: GRIS Y NEGRO – REDE: CINZENTO E PRETA - СЕТЬ: СЕРЫЙ И ЧЕРНЫЙ
- Y - V** = RETE: MARRONE E GRIGIO – MAINS: BROWN AND GRAY – SECTEUR: MARRON ET GRIS – NETZ: BROWN UND GRAU – RED: MARRÓN Y GRIS – REDE: CASTANHA E CINZENTO - СЕТЬ: КОРИЧНЕВЫЙ И СЕРЫЙ
- Z - W** = RETE: NERO E MARRONE – MAINS: BLACK AND BROWN – SECTEUR: NOIR ET MARRON – NETZ: SCHWARZ UND BROWN – RED: NEGRO Y MARRÓN – REDE: PRETA E CASTANHA - СЕТЬ: ЧЕРНЫЙ И КОРИЧНЕВЫЙ
- T – T1** = PROTETTORI TERMICI: MARRONE E GRIGIO - THERMAL PROBE: BROWN AND GRAY - PROTECTIONS THERMIQUES: MARRON ET GRIS – THERMOSCHUTZVORRICHTUNGEN: BROWN UND GRAU - PROTECTORES TÉRMICOS: MARRÓN Y GRIS - PROTECTORES TÉRMICOS: CASTANHA E CINZENTO - ТЕПЛОЗАЩИТНЫЕ УСТРОЙСТВА СТАТОРА: КОРИЧНЕВЫЙ И СЕРЫЙ
- S** = SONDA RILEV. ACQUA: NERO - HUMIDITY PROBE: BLACK - SONDE DE PRÉSENCE D'EAU NOIR – SENSOR: SCHWARZ - SONDA DETEC. AGUA: NEGRO - SONDA DETECTORA DE ÁGUA: PRETA - ЭЛЕКТРОД ДЛЯ КОНТРОЛЯ ПРИСУТСТВИЯ ВОДЫ В МАСЛЯНОЙ КАМЕРЕ: ЧЕРНЫЙ

Apparecchiatura per rilevamento presenza acqua nella camera olio.  
Equipment for reveal presence of water in the oil chamber.  
Équipement pour relevé présence eau dans la chambre d'huile.  
Ausrüstung für decken Vorhandensein des Wassers im Ölraum auf  
Equipamiento para revelar presencia agua en la cámara de aceite.  
O equipamento para revela a presença da água na câmara do óleo  
Электрод для контроля присутствия воды в масляной камере



**SCHEMA DEI COLLEGAMENTI ELETTRICI COLLEGAMENTO STELLA/TRIANGOLO  
ELECTRICAL CONNECTION DIAGRAM STAR/DELTA CONNECTION  
SCHÉMA DES BRANCHEMENTS ÉLECTRIQUES CONNEXION ÉTOILE/TRIANGLE  
SCHEMA DER ELEKTRISCHEN ANSCHLÜSSE STERN-DREIECK ANSCHLUB  
DIAGRAMA DE LAS CONEXIONES ELÉCTRICAS CONEXIÓN ESTRELLA/TRIÁNGULO  
ESQUEMA DAS LIGAÇÕES ELÉCTRICAS LIGAÇÃO ESTRELA/TRIÂNGULO  
ЭЛЕКТРИЧЕСКАЯ СХЕМА ДЛЯ СОЕДИНЕНИЯ ЗВЕЗДА/ТРЕУГОЛЬНИК**

Da collegare al morsetto del rivelatore acqua solo se l'elettropompa è fornita dell'apposito quadro di controllo.  
To be connected to the water-probe only if the pump is equipped with specific control panel.  
A connecter à la borne du détecteur eau seulement si l'électropompe est munie du coffret de commande.  
Der Anschluß an die Klemme der Feuchtigkeitssonde ist nur dann vorzunehmen, wenn die Motorpumpe mit der entsprechenden Schalttafel geliefert wird.  
A conectar al borne del revelador agua solo si la electrobomba dispone del respectivo cuadro de control.  
A ligar ao borne do detector de água só se a electrobomba é fornecida com o respectivo quadro de controle.  
Подсоединяется к клемме датчика воды при условии, что электронасос имеет соответствующий пульт управления.

Cavi a 4 conduttori dell'elettropompa  
- 4 lead electric pump cables - câbles de l'électropompe, a 4 conducteurs - 4 leiter-kabel - cables a 4 conductores de la electrobomba - cabos de 4 condutores da electrobomba - 4-жильный кабель электронасоса

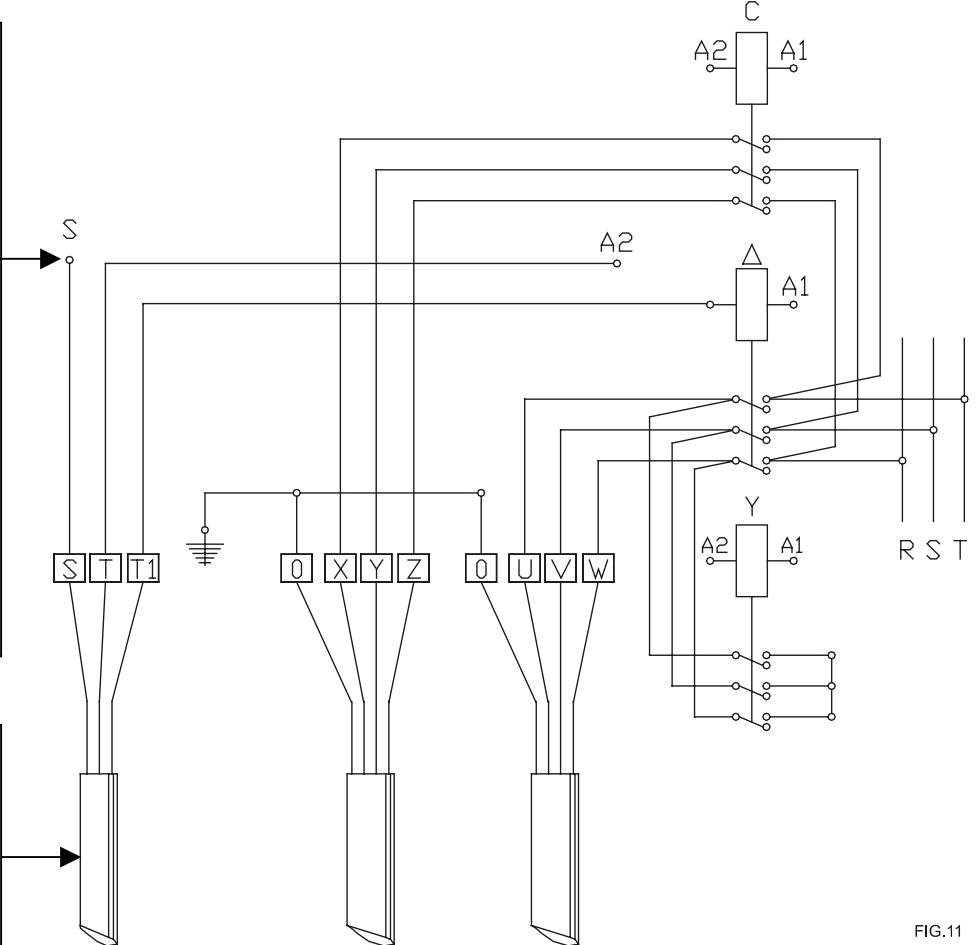
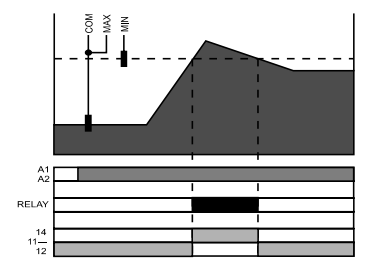
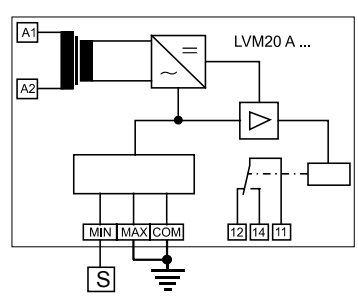

FIG.11

- X - Y - Z** = RETE: GRIGIO, MARRONE E NERO - MAINS: GRAY, BROWN AND BLACK – SECTEUR: GRIS, MARRON ET NOIR – NETZ: GRAU, BROWN UND SCHWARZ – RED: GRIS, MARRÓN Y NEGRO – REDE: CINZENTO, CASTANHA E PRETA - СЕТЬ: СЕРЫЙ, КОРИЧНЕВЫЙ И ЧЕРНЫЙ
- V - W - U** = RETE: GRIGIO, MARRONE E NERO - MAINS: GRAY, BROWN AND BLACK – SECTEUR: GRIS, MARRON ET NOIR – NETZ: GRAU, BROWN UND SCHWARZ – RED: GRIS, MARRÓN Y NEGRO – REDE: CINZENTO, CASTANHA E PRETA - СЕТЬ: СЕРЫЙ, КОРИЧНЕВЫЙ И ЧЕРНЫЙ
- T – T1** = PROTETTORI TERMICI: MARRONE E GRIGIO - THERMAL PROBE: BROWN AND GRAY - PROTECTIONS THERMIQUES: MARRON ET GRIS – THERMOSCHUTZVORRICHTUNGEN: BROWN UND GRAU - PROTECTORES TÉRMICOS: MARRÓN Y GRIS - PROTECTORES TÉRMICOS: CASTANHA E CINZENTO - ТЕПЛОЗАЩИТНЫЕ УСТРОЙСТВА СТАТОРА: КОРИЧНЕВЫЙ И СЕРЫЙ
- S** = SONDA RILEV. ACQUA: NERO - HUMIDITY PROBE: BLACK - SONDE DE PRÉSENCE D'EAU NOIR – SENSOR: SCHWARZ - SONDA DETEC. AGUA: NEGRO - SONDA DETECTORA DE ÁGUA: PRETA - ЭЛЕКТРОД ДЛЯ КОНТРОЛЯ ПРИСУТСТВИЯ ВОДЫ В МАСЛЯНОЙ КАМЕРЕ: ЧЕРНЫЙ

Apparecchiatura per rilevamento presenza acqua nella camera olio.  
Equipment for reveal presence of water in the oil chamber.  
Équipement pour relevé présence eau dans la chambre d'huile.  
Ausrüstung für decken Vorhandensein des Wassers im Ölraum auf  
Equipamiento para relación presencia agua en la cámara de aceite.  
O equipamento para revela a presença da água na câmara do óleo  
Электрод для контроля присутствия воды в масляной камере



**INSTALLAZIONE CON PIEDE DI ACCOPPIAMENTO**  
**INSTALLATION WITH COUPLING FOOT**  
**INSTALLATION AVEC PIED D'ASSEMBLAGE**  
**EINBAU MIT KUPPLUNGSFUSS**  
**INSTALACIÓN CON PIE DE ACOPLAMIENTO**  
**INSTALAÇÃO COM PÉ DE ACOPLAMENTO**  
**УСТАНОВКА С СОЕДИНИТЕЛЬНОЙ ОПОРОЙ**

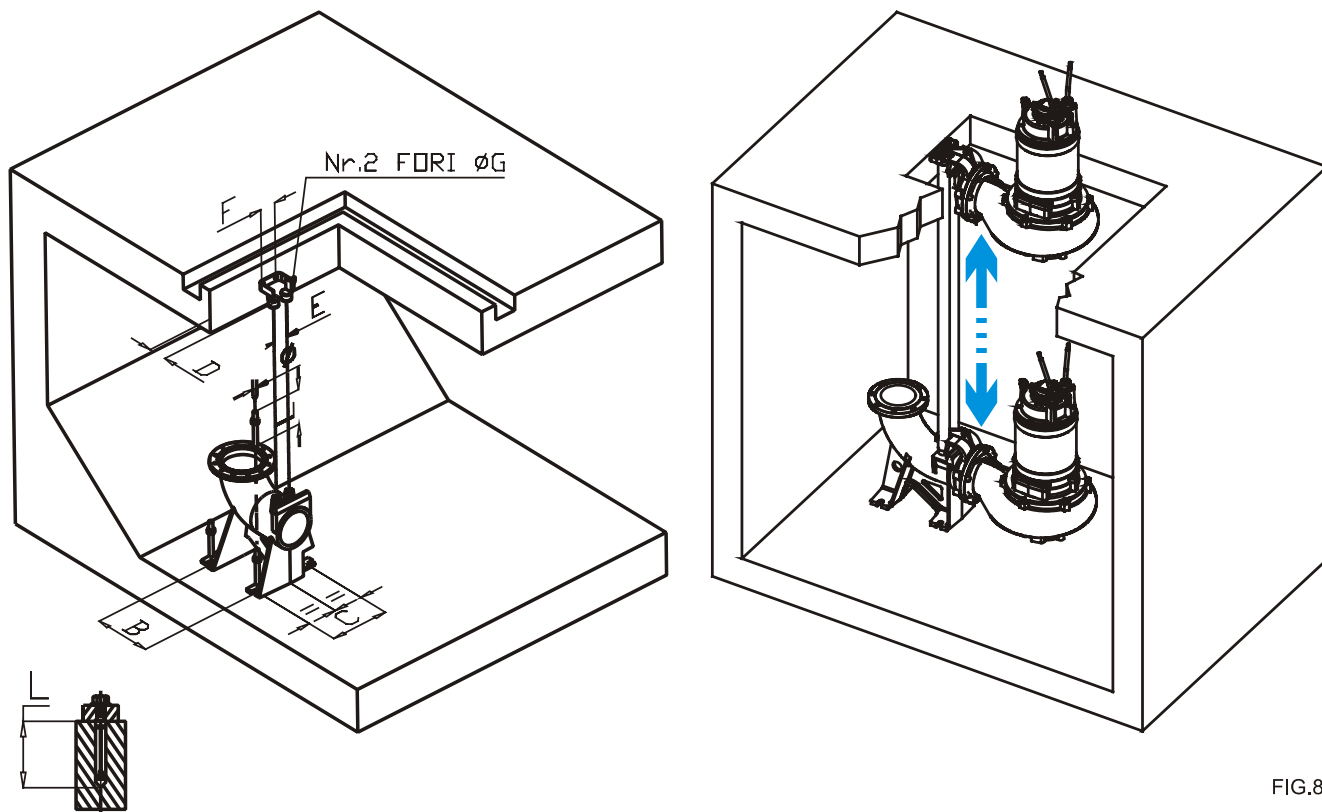

FIG.8

Ref	Descrizione - Description - Description - Beschreibung - Descripción - Description - Описание	DN50 mm	DN65 mm	DN80 mm	DN100 mm	DN150 mm	DN200 mm	DN300 mm
B	Interasse laterale piede - Distance of coupling feet lateral side - Entraxe latéral pied - Achsmaße des Kupplungsfusses in Fließrichtung - Distancia lateral pie de acoplamiento - Entre-eixo lateral pé - Боковое межос. расстояние опоры	110	200	250	250	300	400	500
C	Interasse frontale piede - Distance of coupling feet front-end side - Entraxe frontal pied - Achsmaße in der Breite des Kupplungsfusses - Distancia frontal pie de acoplamiento - Entre-eixo frontal pé - Переднее межос. расстояние опоры	100	120	160	160	200	250	500
D	Distanza supporto tubi - Distance of pipes support - Distance de patte support des tubes - Distanz des Rohrspanners von Schachtwand - Distancia soporte tubos - Distância suporte tubos - Расстояние трубных опор	86	85	85	85	85	85	120
E	Interasse tubi guida - Distance between guide rails - Entraxe tubes guidages - Abstand zwischen den Führungsrohren - Distancia entre los tubos guía - Entre-eixo Tubos guia - Межос. расстояние направляющих труб	35	100	100	100	100	100	125
F	Interasse fori supporto - Distance between support's holes - Entraxe des troux de la patte support - Abstand der Befestigungsbohrungen Rohrspanner - Distancia entre agujeros de soporte - Entre-eixo furos de suporte - Межос. расстояние опоры	52	77,5	77,5	77,5	77,5	77,5	100
L	Lunghezza foro min. - Hole lenght - Longueur du trou - Tiefe der Bohrung für Befestigungsdübel - largo de los agujeros - Comprimento furo min - Мин. длина отверстия	60	80	80	80	80	80	110
Ø	Diametro foro - Hole diameter - Diamètre du trou - Bohrungsdurchmesser - Diámetro agujeros - Diámetro furo - Диаметр отверстия	10	16	16	16	16	20	20
G	Diametro foro supporto - Support hole diameter - Diamètre du trou de la patte superieur - Bohrungsdurchmesser Rohrspanner - Diámetro agujero soporte - Diámetro furo soporte - Диаметр отверстия опоры	8	10	10	10	10	10	12

**INSTALLAZIONE CON PIEDE DI ACCOPPIAMENTO  
 INSTALLATION WITH COUPLING FOOT  
 INSTALLATION AVEC PIED D'ASSEMBLAGE  
 EINBAU MIT KUPPLUNGSFUSS  
 INSTALACIÓN CON PIE DE ACOPLAMIENTO  
 INSTALAÇÃO COM PÉ DE ACOPLAMENTO  
 УСТАНОВКА С СОЕДИНИТЕЛЬНОЙ ОПОРОЙ**

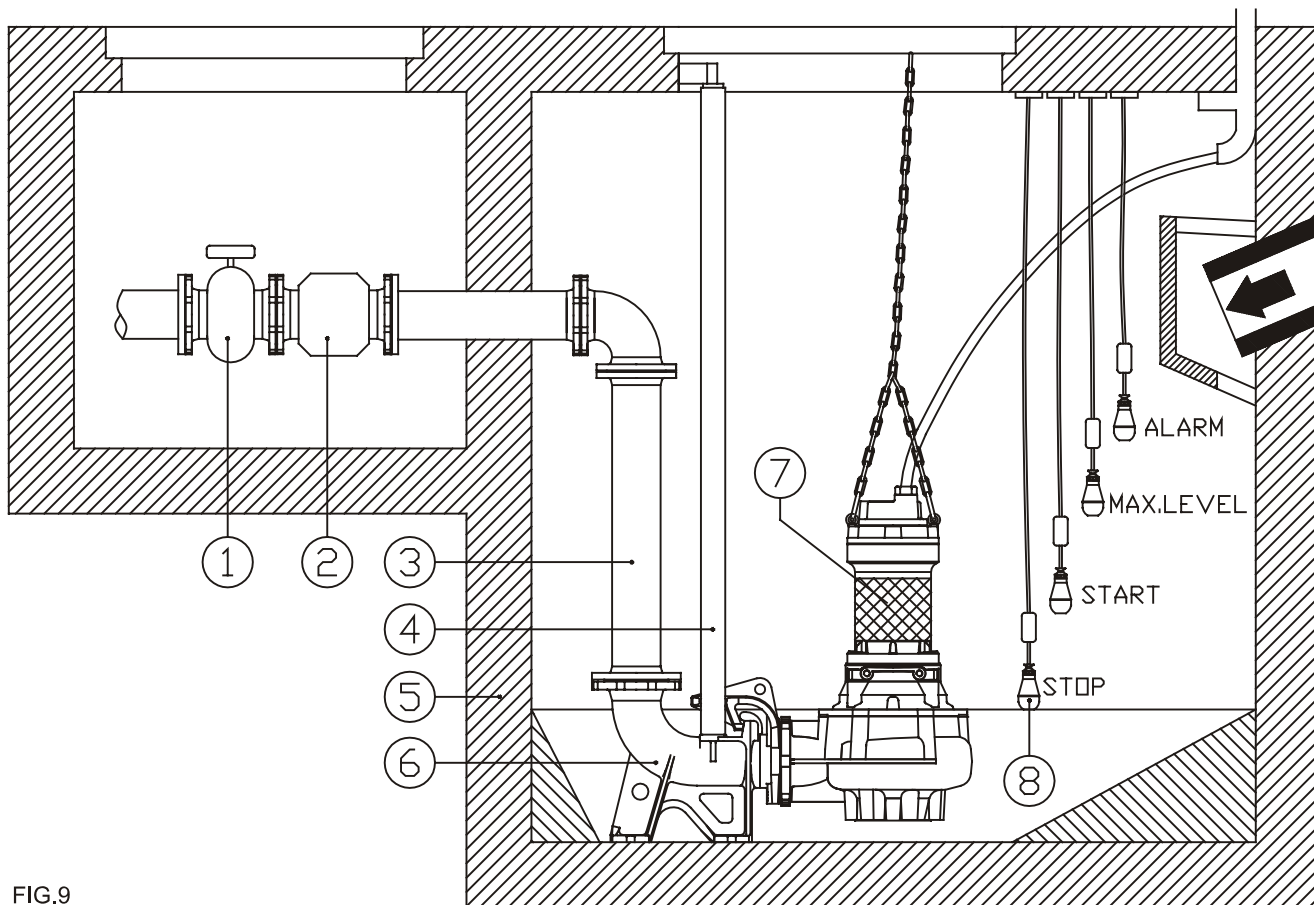

FIG.9

POS.	Descrizione - Description - Description - Beschreibung - Descripción - Descrição - Описание
1	SARACINESCA - GATE VALVE - VANNE - SCHIEBER - VÁLVULA DE COMPUERTA - SARACINESCA - ЗАСЛОНКА
2	VALVOLA DI RITEGNO - CHECK VALVE - SOUPAPE DE RÉTENTION - RÜCKSCHLAGVENTIL - VÁLVULA DE RETENCIÓN - VÁLVULAS DE RETENÇÃO - СТОПОРНЫЙ КЛАПАН
3	TUBO DI MANDATA - DELIVERY PIPE - TUBE DE REFOULEMENT - DRUCKLEITUNG - TUBO DE IMPULSIÓN - TUBO DE DESCARGA - ПОДАЮЩАЯ ТРУБА
4	TUBO DI GUIDA - GUIDE TUBE - TUBE DE GUIDAGE - FÜHRUNGSROHR - TUBO DE GUÍA - TUBO DE GUIA - НАПРАВЛЯЮЩАЯ ТРУБА
5	POZZETTO - SUMP - PUISARD - GULLY - SUMIDERO - FOSSA DE RETENÇÃO - ПРИЯМОК
6	PIEDE DI ACCOPPIAMENTO - COUPLING FOOT - PIED D'ASSEMBLAGE - KUPPLUNGSFUSS - PIE DE ACOPLAMIENTO - PÉ DE ACOPLAMENTO - СОЕДИНИТЕЛЬНАЯ ОПОРА
7	POMPA SOMMERGIBILE - SUBMERSIBLE PUMP - POMPE SUBMERSIBLE - TAUCHMOTORPUMPE - BOMBA SUMERGIBLE - BOMBA SUBMERSÍVEL - ПОГРУЖНОЙ НАСОС
8	REGOLATORI DI LIVELLO (GALLEGGIANTI) - LEVEL REGULATOR (FLOATS) - RÉGULATEURS DE NIVEAU (FLOTTEURS) - NIVEAUREGLER (SCHWIMMERSSCHALTER) - REGULADORES DE NIVEL (FLOTANTES) - REGULADORES DE NÍVEL (FLUTUANTES) - РЕГУЛЯТОРЫ УРОВНЯ (ПОПЛАВКИ)

POSIZIONE DELLA CATENA DI SOLLEVAMENTO  
POSITION OF LIFTING CHAIN  
POSITION DE LA CHAÎNE DE LEVAGE  
POSITION DER ANHEBENDEN KETTE  
POSICIÓN DE LA CADENA DE ELEVACIÓN  
POSICÃO DO LEVANTAMENTO CADEIA  
РАСПОЛОЖИТЬ ЦЕПИ

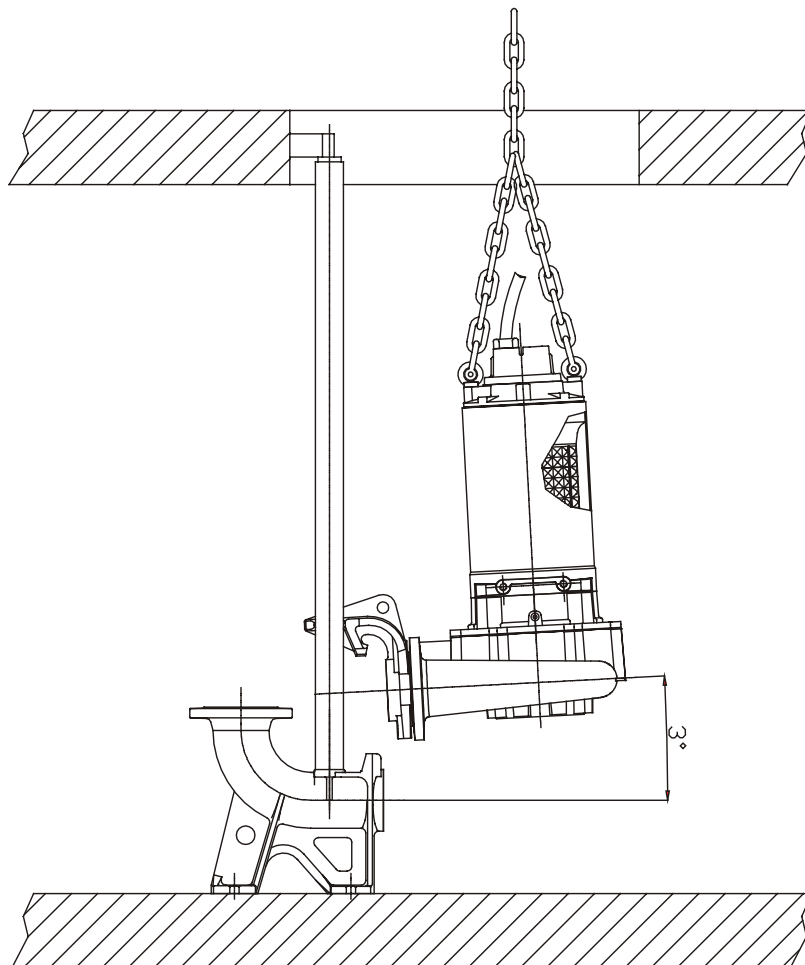
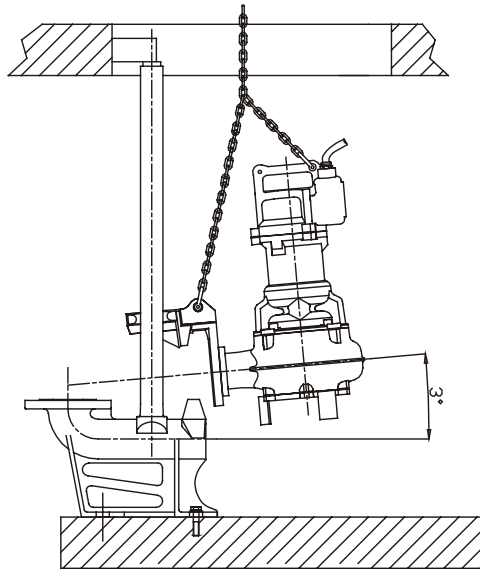

FIG.12





## **I DICHIARAZIONE DI CONFORMITÀ**

Noi CALPEDA S.p.A. dichiariamo sotto la nostra esclusiva responsabilità che le Pompe GMV, GMC, GMN, GMG, tipo e numero di serie riportati in targa, sono conformi a quanto prescritto dalle Direttive 2004/108/CE, 2006/42/CE, 2006/95/CE e dalle relative norme armonizzate.

## **GB DECLARATION OF CONFORMITY**

We CALPEDA S.p.A. declare that our Pumps GMV, GMC, GMN, GMG, with pump type and serial number as shown on the name plate, are constructed in accordance with Directives 2004/108/EC, 2006/42/EC, 2006/95/EC and assume full responsibility for conformity with the standards laid down therein.

## **D KONFORMITÄTSERKLÄRUNG**

Wir, das Unternehmen CALPEDA S.p.A., erklären hiermit verbindlich, daß die Pumpen GMV, GMC, GMN, GMG, Typbezeichnung und Fabrik-Nr. nach Leistungsschild den EG-Vorschriften 2004/108/EG, 2006/42/EG, 2006/95/EG entsprechen.

## **F DECLARATION DE CONFORMITE**

Nous, CALPEDA S.p.A., déclarons que les Pompes GMV, GMC, GMN, GMG, modèle et numero de série marqués sur la plaque signalétique sont conformes aux Directives 2004/108/CE, 2006/42/CE, 2006/95/CE.

## **E DECLARACION DE CONFORMIDAD**

En CALPEDA S.p.A. declaramos bajo nuestra exclusiva responsabilidad que las Bombas GMV, GMC, GMN, GMG, modelo y numero de serie marcados en la placa de características son conformes a las disposiciones de las Directivas 2004/108/CE, 2006/42/CE, 2006/95/CE.

## **DK OVERENSSTEMMELSESERKLÆRING**

Vi CALPEDA S.p.A. erklærer hermed at vore pumper GMV, GMC, GMN, GMG, pumpe type og serie nummer vist på typeskiltet er fremstillet i overensstemmelse med bestemmelserne i Direktiv 2004/108/EC, 2006/42/EC, 2006/95/EC og er i overensstemmelse med de heri indeholdte standarder.

## **P DECLARAÇÃO DE CONFORMIDADE**

Nós, CALPEDA S.p.A., declaramos que as nossas Bombas GMV, GMC, GMN, GMG, modelo e número de série indicado na placa identificadora são construídas de acordo com as Directivas 2004/108/CE, 2006/42/CE, 2006/95/CE e somos inteiramente responsáveis pela conformidade das respectivas normas.

## **NL CONFORMITEITSVERKLARING**

Wij CALPEDA S.p.A. verklaren hiermede dat onze pompen GMV, GMC, GMN, GMG, pomptype en serienummer zoals vermeld op de typeplaat aan de EG-voorschriften 2004/108/EU, 2006/42/EU, 2006/95/EU voldoen.

## **SF VAKUUTUS**

Me CALPEDA S.p.A. vakuutamme että pumppumme GMV, GMC, GMN, GMG, malli ja valmistusnumero tyypikilvcstä, ovat valmistettu 2004/108/EU, 2006/42/EU, 2006/95/EU direktiivien mukaisesti ja CALPEDA ottaa täyden vastuun siitä, että tuotteet vastaavat näitä standardeja.

## **S EU NORM CERTIFIKAT**

CALPEDA S.p.A. intyggar att pumpar GMV, GMC, GMN, GMG, pumpstyp och serienummer, visade på namnplåten är konstruerade enligt direktiv 2004/108/EC, 2006/42/EC, 2006/95/EC. Calpeda åtar sig fullt ansvar för överensstämmelse med standard som fastställts i dessa avtal.

## **GR ΔΗΛΩΣΗ ΣΥΜΦΩΝΙΑΣ**

Εμείς ως CALPEDA S.p.A. δηλώνουμε ότι οι αντλίες μας αυτές NR, NR4, NRM, NR4M, με τύπο και αριθμό σειράς κατασκευής όπου αναγράφεται στην πινακίδα της αντλίας, κατασκευάζονται σύμφωνα με τις οδηγίες 2004/108/ΕΟΚ, 2006/42/ΕΟΚ, 2006/95/ΕΟΚ, και αναλαμβάνουμε πλήρη υπευθυνότητα για συμφωνία (συμμόρφωση), με τα στάνταρς των προδιαγραφών αυτών.

## **TR UYGUNLUK BEYANI**

Bizler CALPEDA S.p.A. firması olarak GMV, GMC, GMN, GMG, Pompalarımızın, 2004/108/EC, 2006/42/EC, 2006/95/EC, direktiflerine uygun olarak imal edildiklerini beyan eder ve bu standartlara uygunluğuna dair tüm sorumluluğu üstleniriz.

## **RU Декларация соответствия**

Компания "Calpeda S.p.A." заявляет с полной ответственностью, что насосы серий GMV, GMC, GMN, GMG, тип и серийный номер которых указывается на заводской табличке соответствуют требованиям нормативов 2004/108/CE, 2006/42/CE, 2006/95/CE.

Montorso Vicentino, 01.2010

Il Presidente

Licia Mettifogo



Calpeda s.p.a. - Via Roggia di Mezzo, 39 - 36050 Montorso Vicentino - Vicenza / Italia  
Tel. +39 0444 476476 - Fax +39 0444 476477 - E.mail: info@calpeda.it www.calpeda.com