

Construction

Close-coupled gear pumps (rotary pumps).
Pump casing with suction and delivery connections with the same diameter and on the same axis (in-line execution).

Applications

For fuel oil and liquids with lubricating properties.

Operating conditions

Kinematic viscosity from 30 mm²/s (4°E) to 120 mm²/s (15°E).
Liquid temperature up to 90 °C.
Ambient temperature up to 40 °C.
Total suction lift up to 4 m.
Continuous duty.

Motor

4-pole induction motor, 50 Hz (n = 1450 rpm).

I, IR, IRR: three-phase 230/400 V ± 10%.

IM: single-phase 230 V ± 10%.

Insulation class F.

Protection IP 54.

Constructed in accordance with: EN 60034-1;

EN 60335-1, EN 60335-2-41.

Materials

Components	Materials
Pump casing	Cast iron GJL 200 EN 1561
Gears	Steel 18 Ni Cr Mo 5 UNI 8550
Shafts	Steel 18 Ni Cr Mo 5 UNI 8550
Radial shaft seal ring	FPM

Special features on request

- Other voltages.
- Frequency 60 Hz (as per 60 Hz data sheet).
- Protection IP 55.
- Higher ambient temperatures.

Performance n ≈ 1450 rpm

	3 ~		230 V		400 V	1 ~	230 V		P ₁	P ₂		n	Q	m ³ /h	
		A	A	A	kW		kW	HP		rpm	l/min			0,6	
I	25/4/A	1,4	0,8	IM25/4/A	2,1	0,4	0,25	0,34	1450	Δp bar	2	10	2,5	5	
IR	25/4/A	2,1	1,2				0,37	0,5	1450						
IRR	25/4/E	3,3	1,9				0,75	1	1450						

P₁ Max. power input.

P₂ Rated motor power output.

Δp Differential pressure.

Dimensions and weights

I 25/4/A: 10 kg
IM 25/4/A: 11,7 kg
IR 25/4/A: 11,6 kg

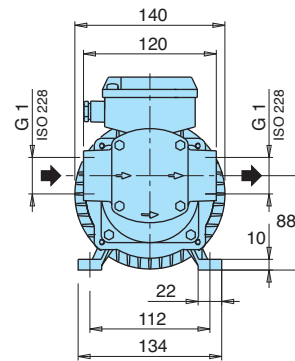
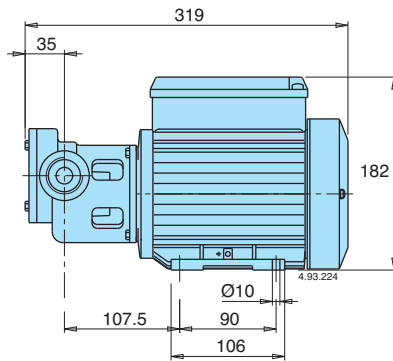

IRR 25/4E: 15,8 kg

