



Construction

Pump casing with suction and delivery connections with the same diameter and on the same axis (in-line).

Materials:

Pump casing	Cast iron
Impeller	Stainless steel
Shaft	Stainless steel

Applications

For clean liquids, without abrasives, which are non-aggressive for the pump materials (contents of solids up to 0.2%).

For heating, conditioning, cooling and circulation plants.

For civil and industrial applications.

When low noise operation is required.

Operating conditions

Liquid temperature from -10 °C to +120 °C (in short-time duty up to + 140 °C).

Ambient temperature up to 40 °C.

Maximum glycol quantity: 50% (Mixture with more than 20% glycol content require rechecking of the pumping data).

Maximum permissible working pressure 6/10 bar.

TYPE	Minimum suction pressure: bar		
	Temperature		
	50 °C	80 °C	110 °C
NC 40	0,05	0,8	1,4
NC 50	0,3	1	1,6
NC 65	0,3	1	1,6
NC 80	0,3	1	1,6

Motor

2-4-pole induction motor, 50 Hz.

Three adjustable speeds.

NC: three-phase 230V or 400 V.

NCM: single-phase 230 V.

Insulation class H.

Protection IP 43.

Installation

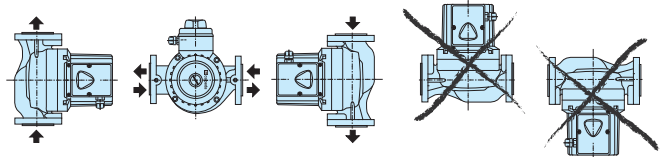

Cross section drawings

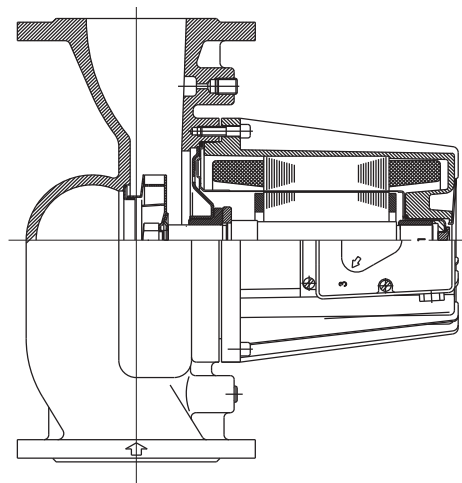

Designation

NC (M) 4 40 - 60 / 250

Series	NC (M)
Single-phase motor	(M)
4-pole motor	4
DN ports in mm	40 - 60
Max. head in dm	/ 250
connection size mm	

Coverage chart

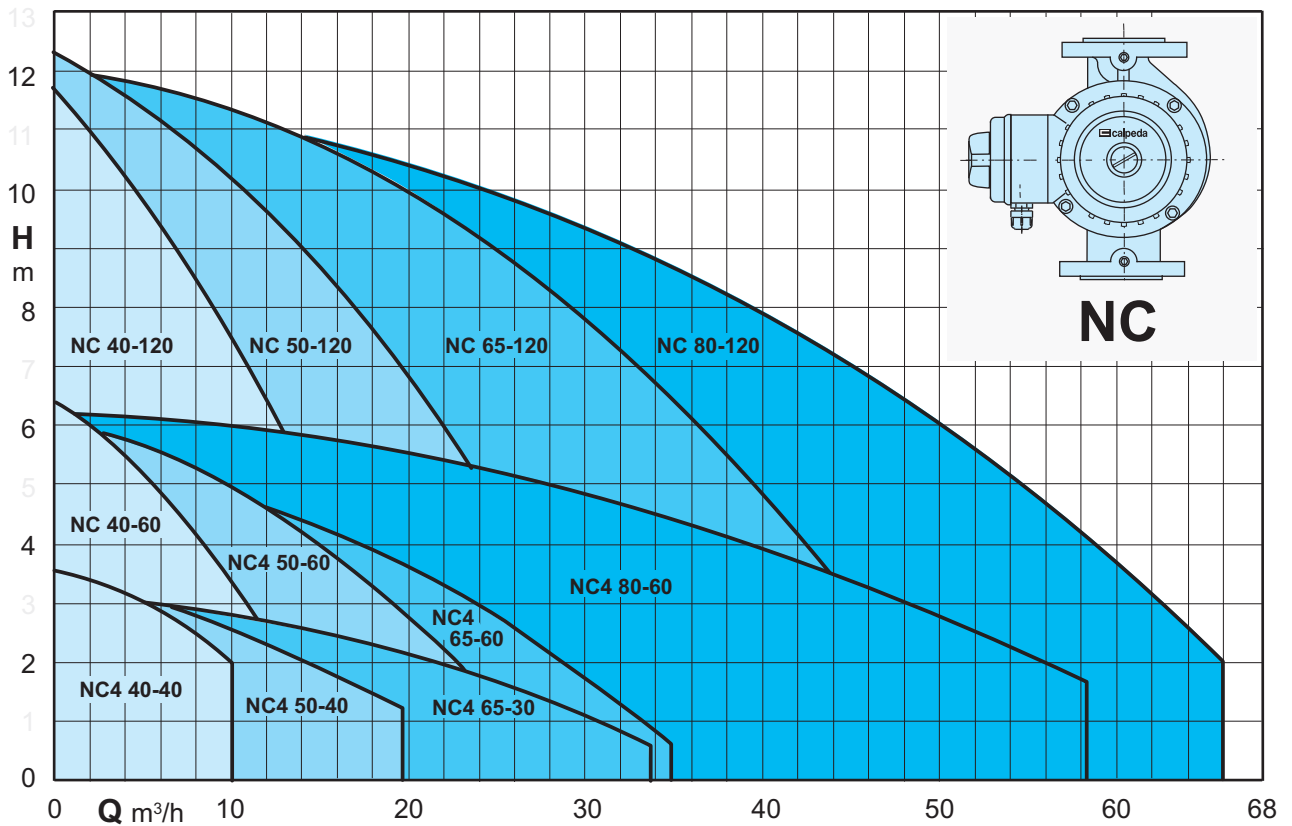

Tolerances according to ISO 9906, annex A.

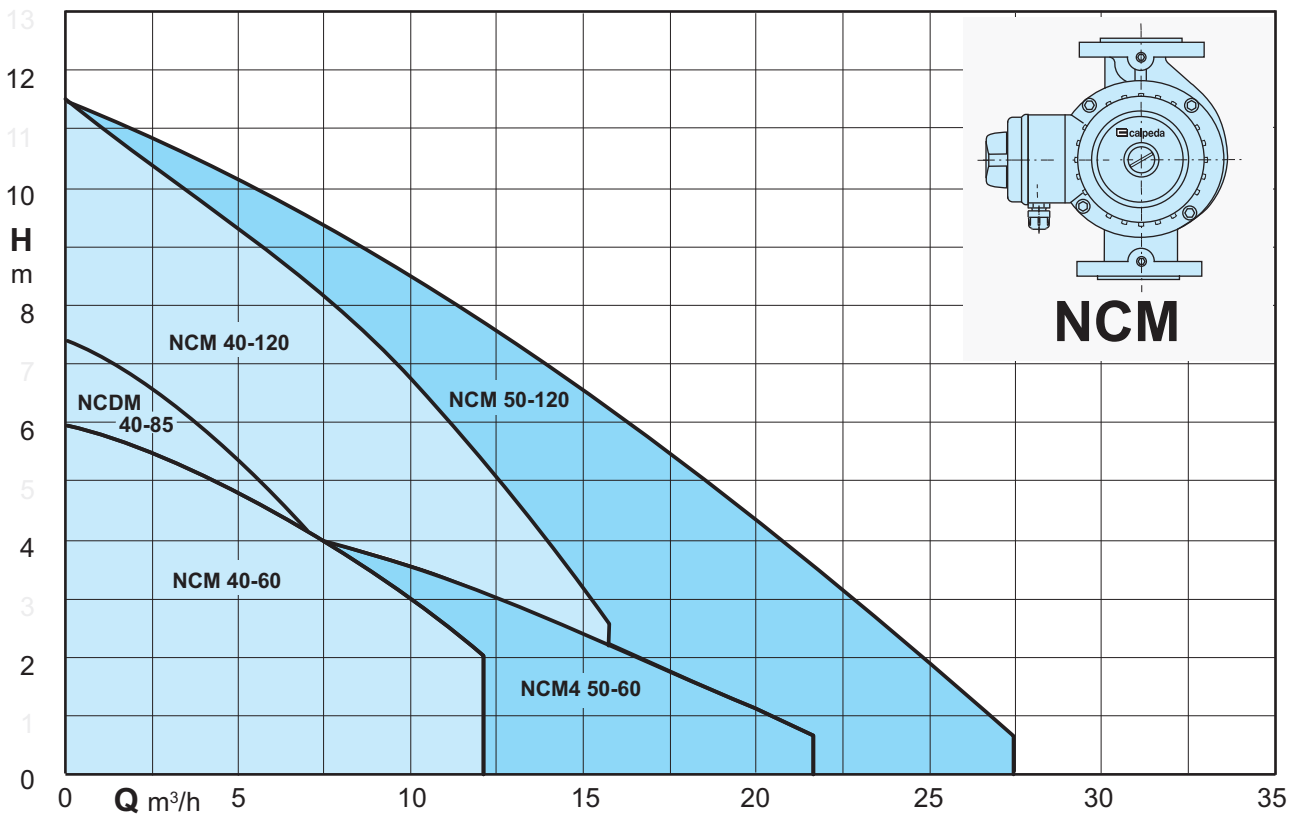

Tolerances according to ISO 9906, annex A.

Characteristic curves, dimensions and weights

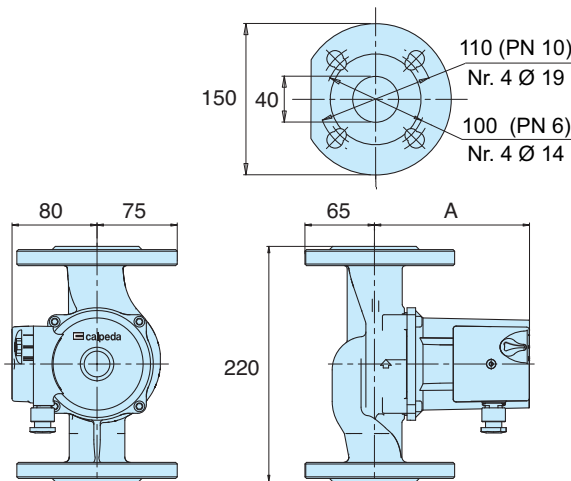
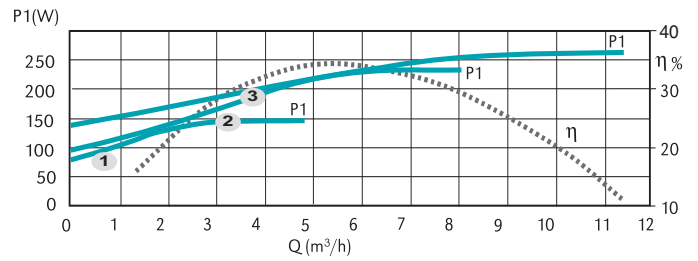
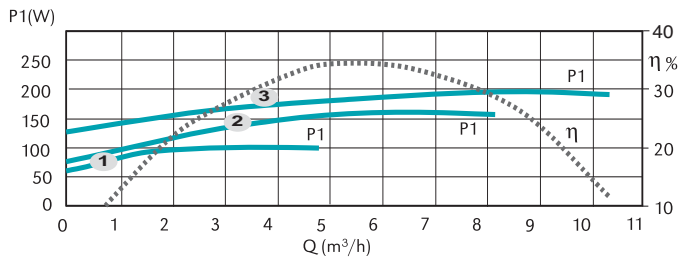
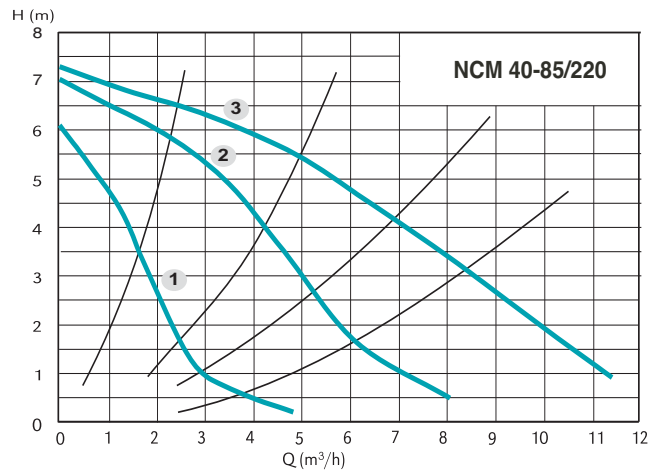
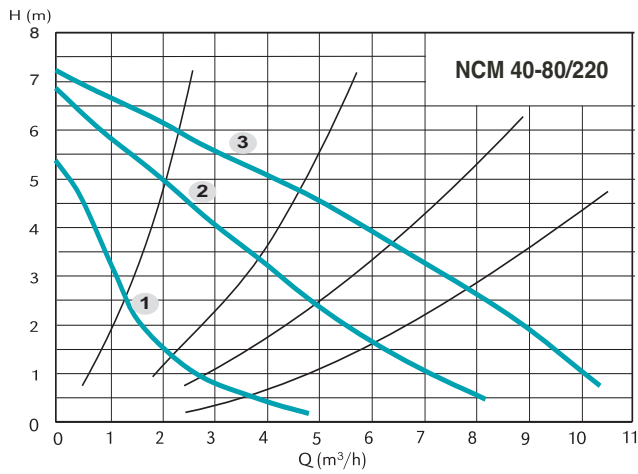

TYPE	DN	PN	N° Poli		Pos.	P1 (W)	1x 230 V [A]	A [mm]	[kg]
			2	4					
NCM 40-80/220	40	6/10	✓		3	206	0,91	150	8,1
					2	185	0,88		
					1	120	0,60		
NCM 40-85/220	40	6/10	✓		3	277	1,20	175	8,8
					2	250	1,16		
					1	172	0,85		

Characteristic curves, dimensions and weights

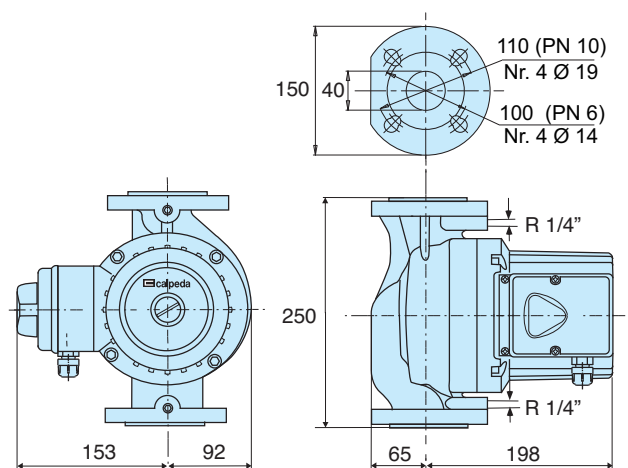
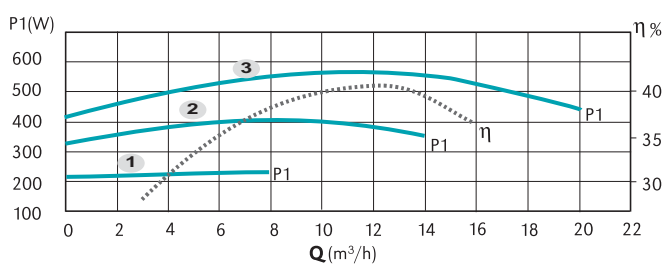
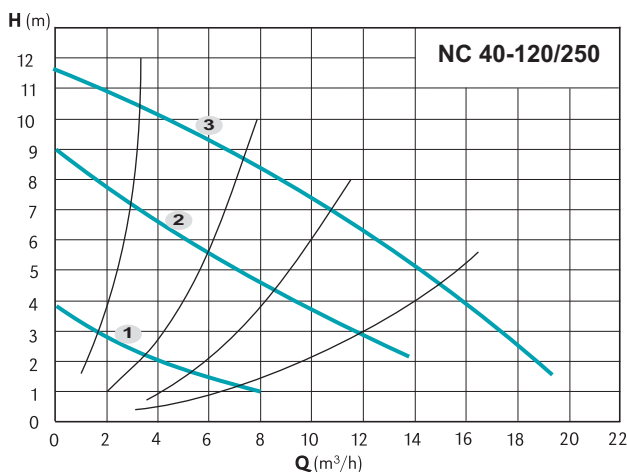
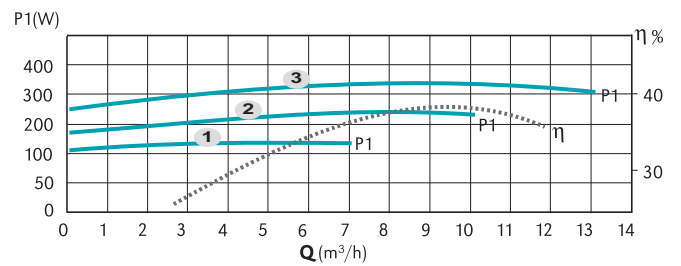
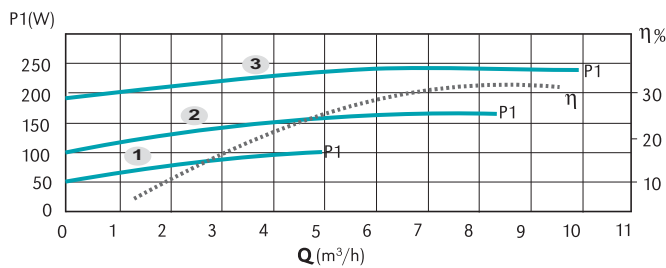
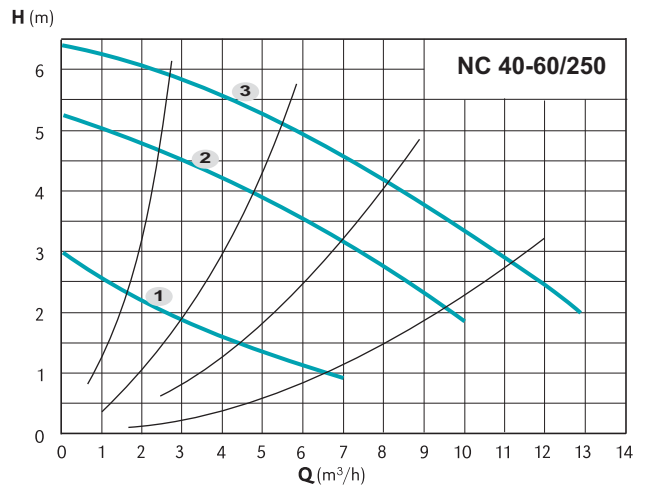
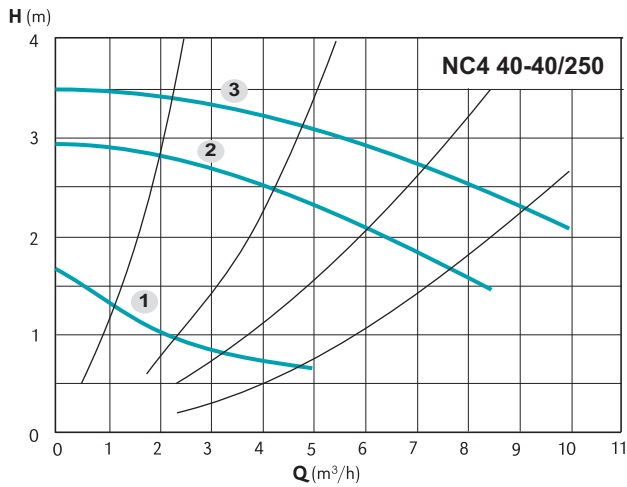

TYPE	DN	PN	N° Poli	2	4	Pos.	1/min	P1 (W)	3x 400 V [A]	[kg]
NC4 40-40/250	40	6/10	✓	3	1440	240	0,76	17,0		
				2	1200	160	0,24			
				1	660	100	0,11			
NC 40-60/250	40	6/10	✓	3	2790	320	0,74	17,5		
				2	2240	240	0,36			
				1	1440	140	0,18			
NC 40-120/250	40	6/10	✓	3	2820	560	1,16	19,0		
				2	2200	400	0,64			
				1	1250	220	0,26			

Characteristic curves, dimensions and weights

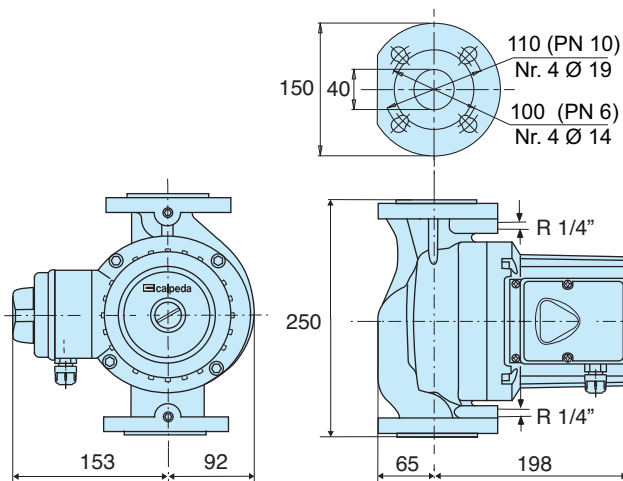
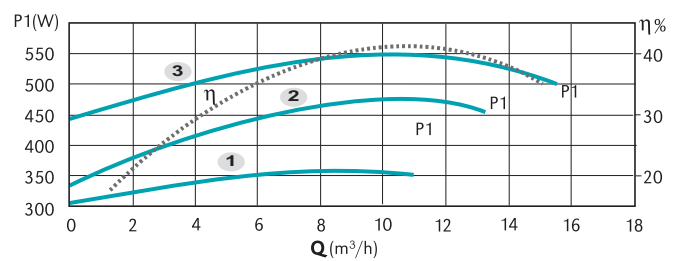
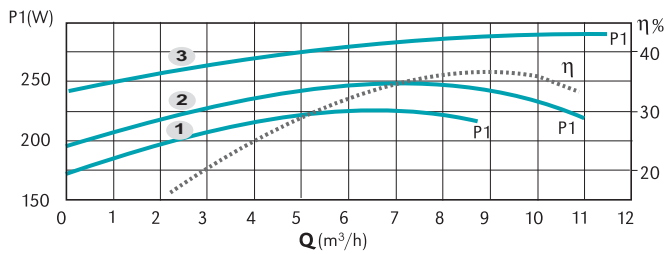
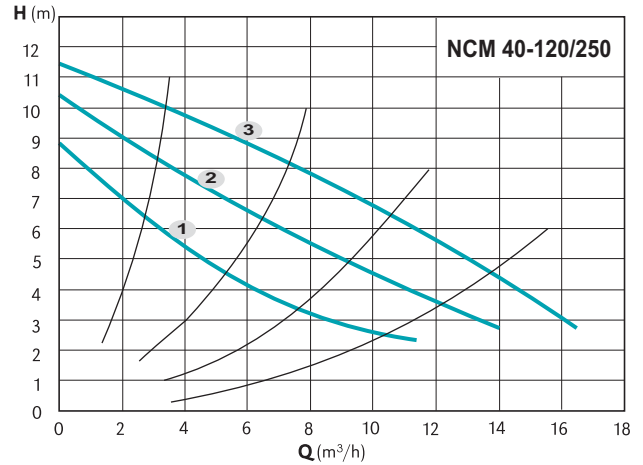
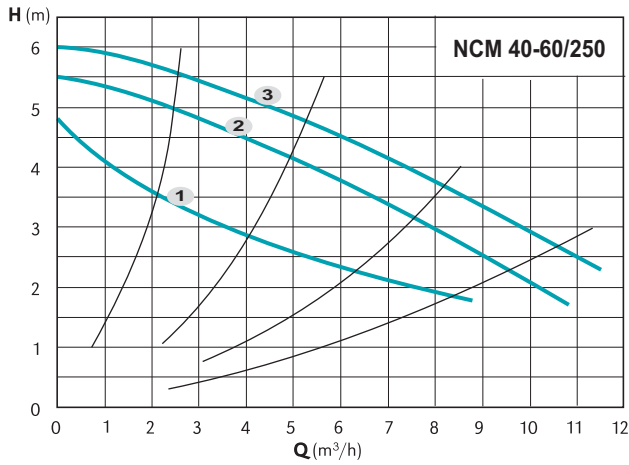

TYPE	DN	PN	N° Poli		Pos.	1/min	P1 (W)	1x 230 V [A]	[kg]
			2	4					
NCM 40-60/250	40	6/10	✓		3	2690	285	1,20	17,5
				✓	2	2360	245	1,18	
				✓	1	1820	225	1,15	
NCM 40-120/250	40	6/10	✓		3	2750	550	2,35	19,0
				✓	2	2100	475	2,30	
				✓	1	1270	355	1,85	

Characteristic curves, dimensions and weights

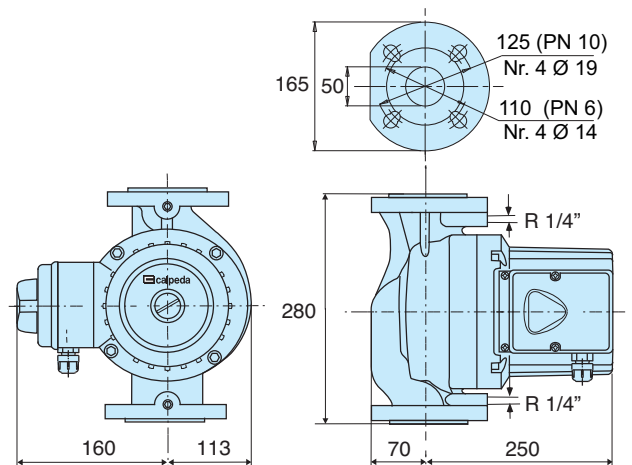
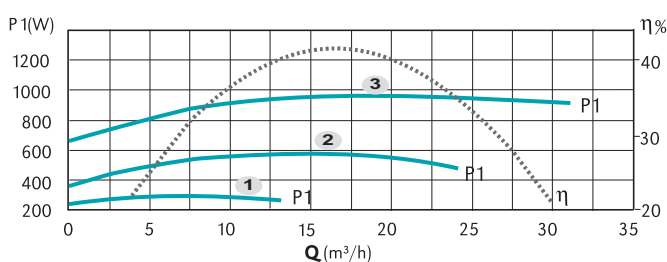
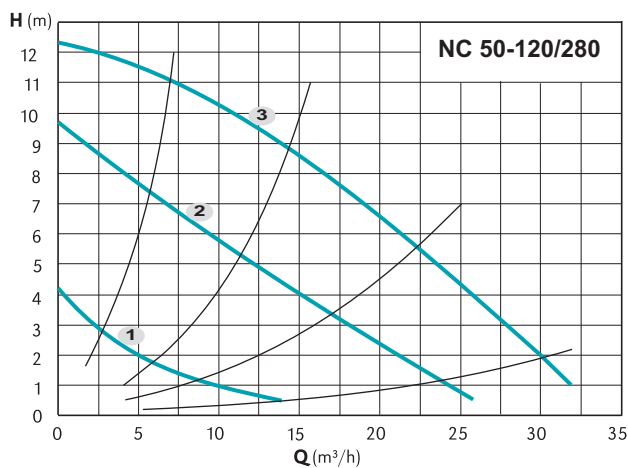
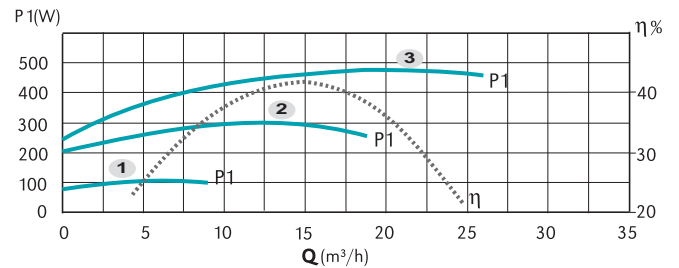
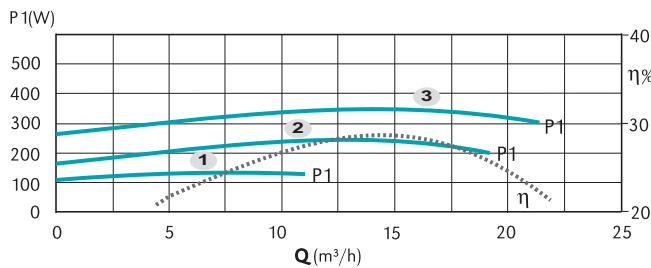
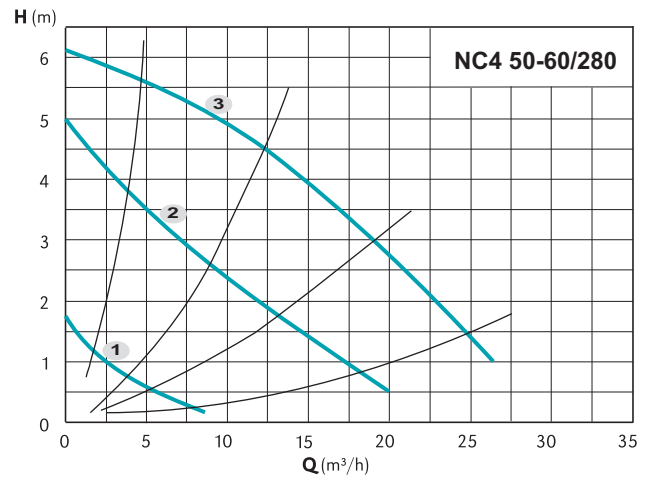
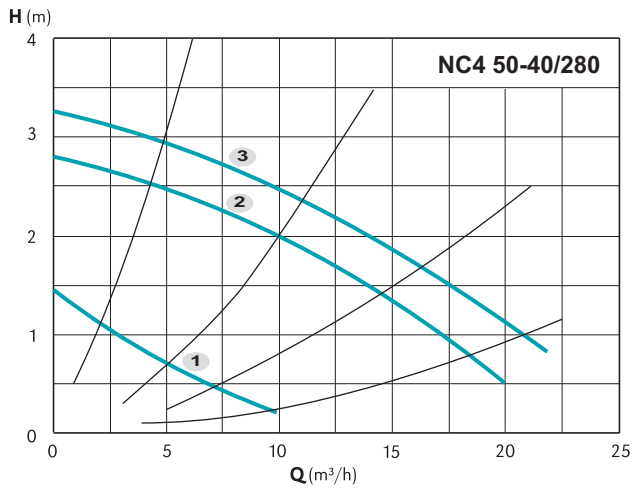

TYPE	DN	PN	N° Poli		1/min	P1 (W)	3x 400 V [A]	[kg]
			2	4				
NC4 50-40/280	50	6/10	✓		3	1450	340	1,05
					2	1220	240	0,44
					1	620	120	0,22
NC4 50-60/280	50	6/10	✓		3	1400	470	1,15
					2	1000	300	0,55
					1	560	100	0,20
NC 50-120/280	50	6/10	✓		3	2800	950	1,73
					2	2330	540	1,05
					1	1270	265	0,46

Characteristic curves, dimensions and weights

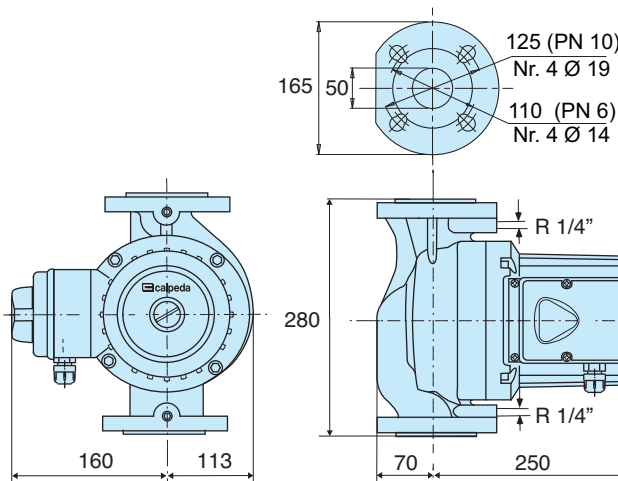
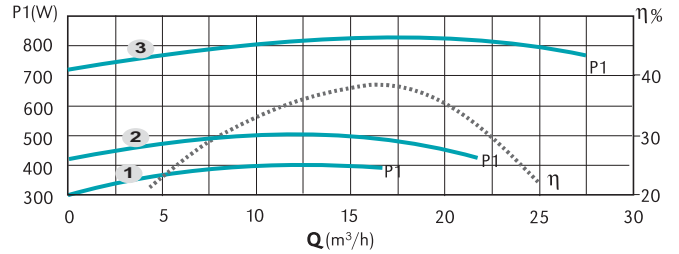
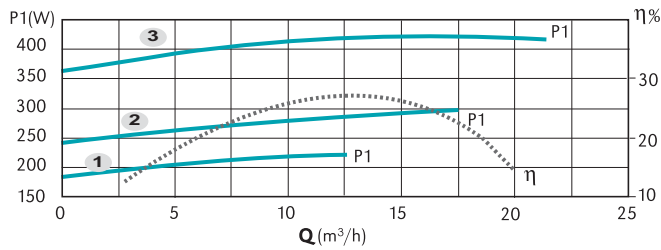
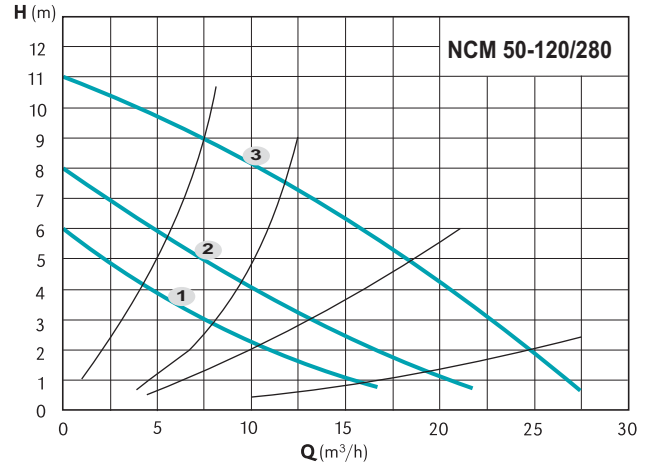
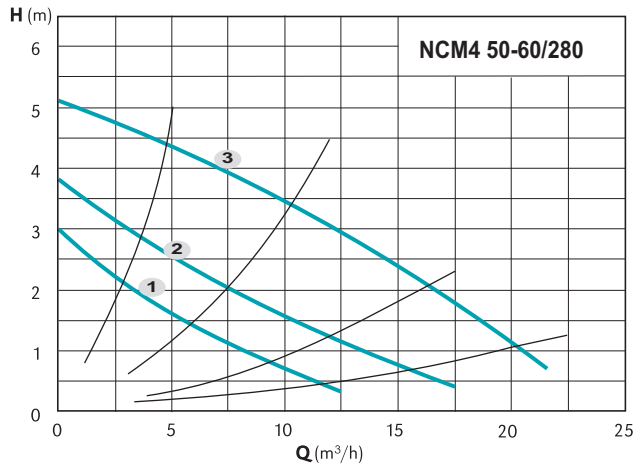

TYPE	DN	PN	N° Poli		Pos.	1/min	P1 (W)	1x 230 V [A]	[kg]
			2	4					
NCM4 50-60/280	50	6/10	✓		3	1260	415	1,8	24,5
					2	1030	300	1,3	
					1	740	230	1,0	
NCM 50-120/280	50	6/10	✓		3	2720	830	3,6	24,5
					2	1870	480	2,1	
					1	1450	390	1,7	

Characteristic curves, dimensions and weights

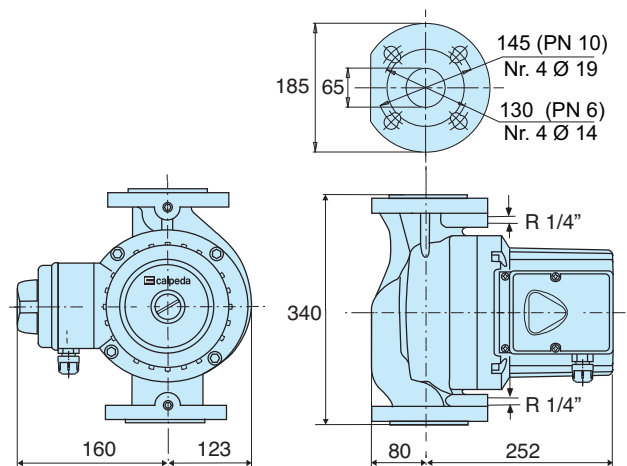
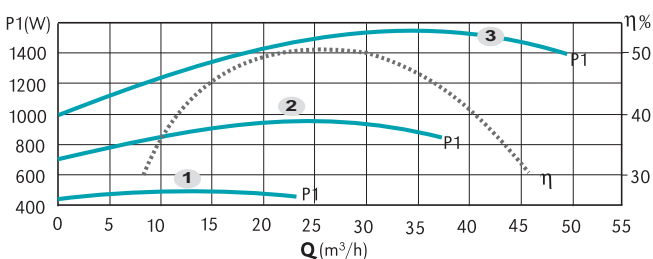
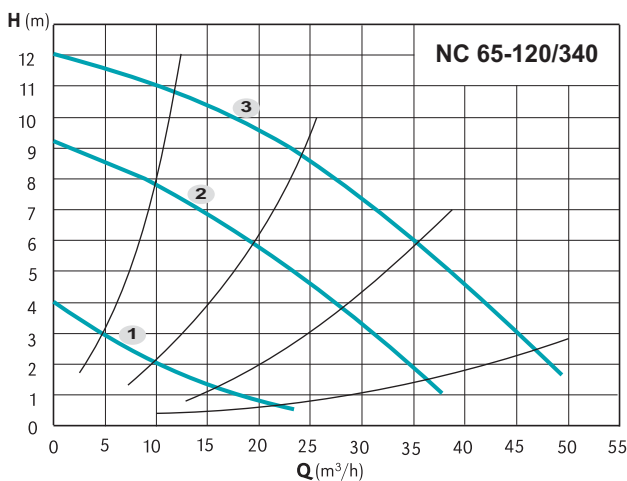
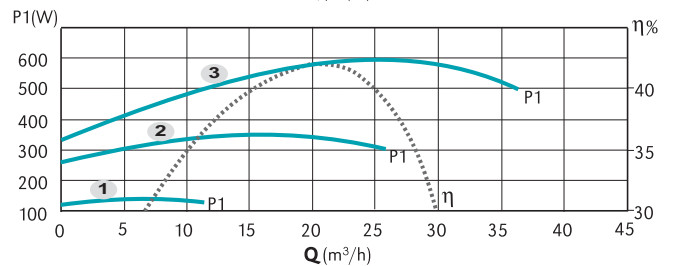
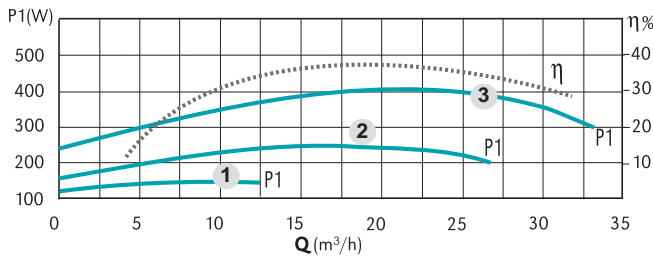
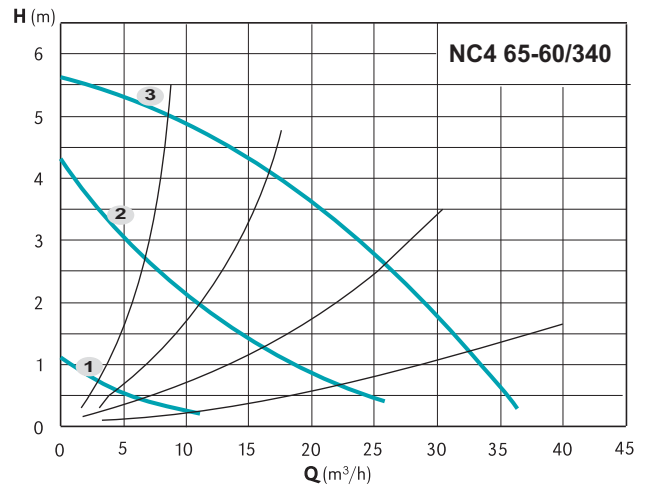
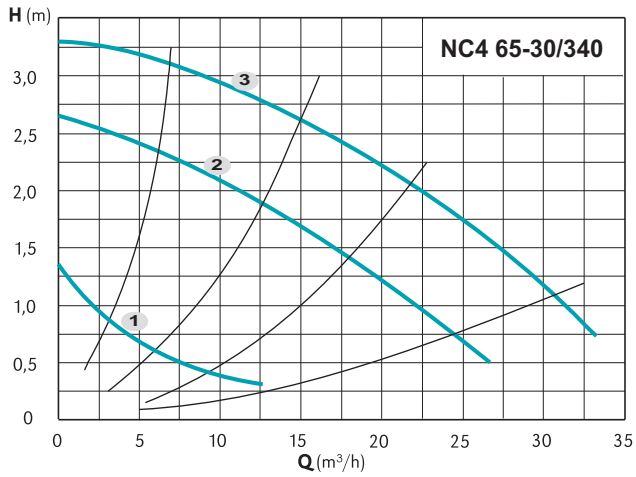

TYPE	DN	PN	N° Poli		1/min	P1 (W)	3x 400 V [A]	[kg]
			2	4				
NC4 65-30/340	65	6/10	✓		3	1430	400	1,10
					2	1150	260	0,50
					1	600	120	0,22
NC4 65-60/340	65	6/10	✓		3	1370	600	1,25
					2	950	360	0,64
					1	450	120	0,22
NC 65-120/340	65	6/10	✓		3	2810	1560	2,80
					2	2200	960	1,70
					1	1250	460	0,84

Characteristic curves, dimensions and weights

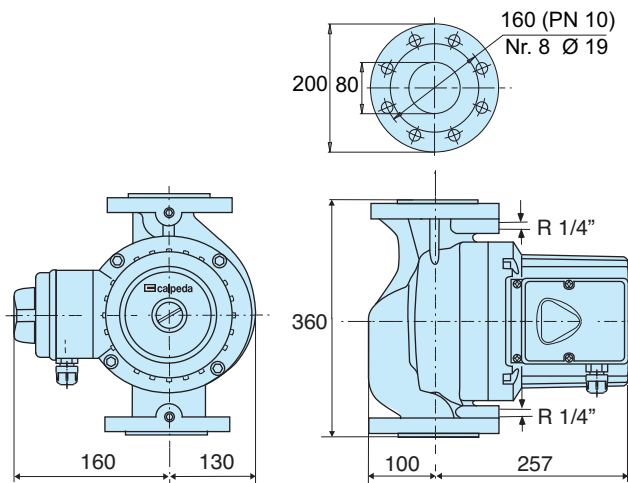
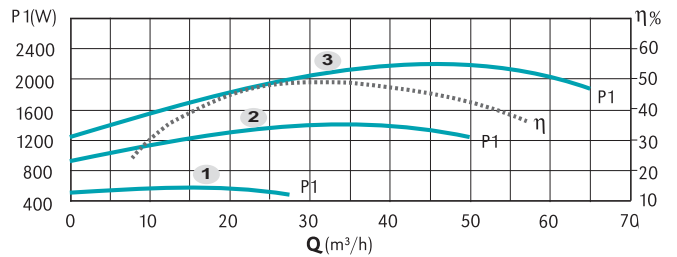
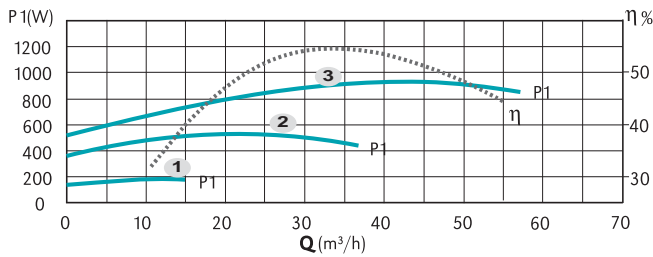
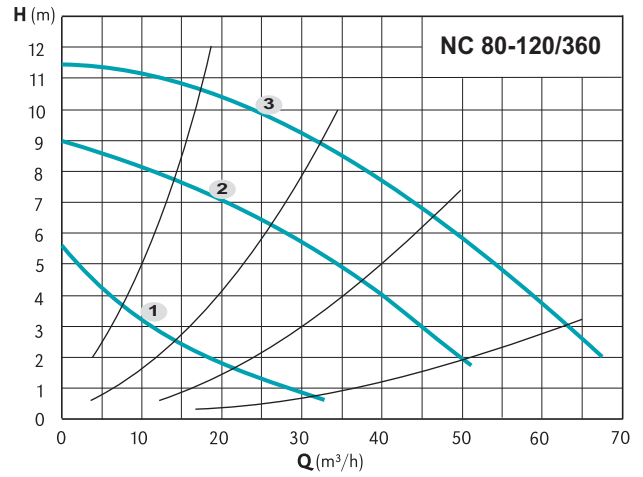
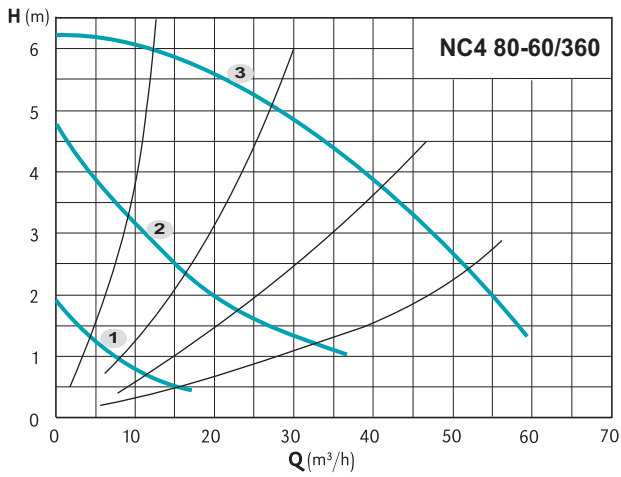

TYPE	DN	PN	N° Poli 2 4	Pos.	1/min	P1 (W)	3x 400 V	
							[A]	[kg]
NC4 80-60/360	80	10	✓	3	1350	960	2,20	33,5
				2	1000	560	1,10	
				1	600	200	0,38	
NC 80-120/360	80	10	✓	3	2800	2200	3,80	34,5
				2	2160	1400	2,40	
				1	1200	550	1,05	