

Construction

Horizontal multi-stage close coupled pumps in **chrome-nickel stainless steel**.

Compact and robust construction, with compact lantern bracket and motor with feet.

Single-piece barrel casing, with front suction port above pumps axis and radial delivery at top.

Filling and draining plugs on the middle of the pump, accessible from any side (like the terminal box).

Applications

For water supply.

For clean liquids, without abrasives, which are non-aggressive for stainless steel (with suitable seal materials, on request).

Universal pump, for civil and industrial applications, for garden use and irrigation.

Operating conditions

Liquid temperature from - 15 °C to + 110 °C.

Ambient temperature up to 40 °C.

Maximum permissible pressure in the pump casing: 10 bar.

Motor

2-pole induction motor, 50 Hz (n = 2900 rpm).

MXH: three-phase 230/400 V ± 10% up to 3 kW;
400/690 V ± 10% from 3,7 to 4 kW.

MXHM: single-phase 230 V ± 10%, with thermal protector.
Capacitor inside the terminal box.

Insulation class F.

Protection IP 54.

Constructed in accordance with: EN 60034-1.

Special features on request

- Pump with Victaulic ports (MXH-V).
- Pump with flanged ports (MXH-F).
- Other voltages.
- Frequency 60 Hz (as per 60 Hz data sheet).
- Protection IP 55.
- Special mechanical seal
- Seal rings in FPM.
- Higher or lower ambient temperatures.

Materials

Component	Material
Pump casing	Chrome-nickel steel AISI 304
Stage casing	Chrome-nickel steel AISI 304
Wear ring	PTFE
Impeller	Chrome-nickel steel AISI 304
Casing cover	Chrome-nickel steel AISI 304
Spacer sleeve	Chrome-nickel steel AISI 304
Pump shaft	Chrome-nickel steel AISI 316
Plug	Chrome-nickel steel AISI 303
Mechanical seal with seat according to ISO 3069-KU	Ceramic alumina, carbon, EPDM (Other materials on request)

Coverage chart n = 2900 rpm

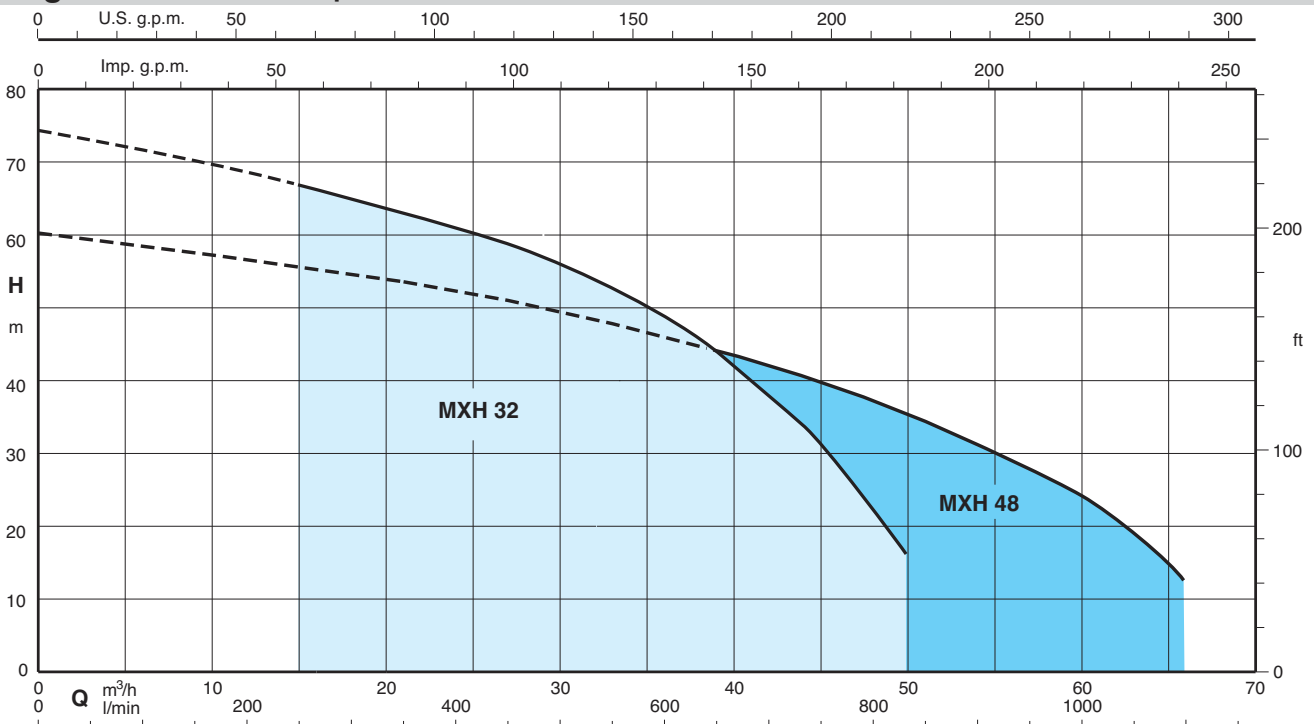

Performance $n \approx 2900$ rpm

	3 ~		P ₂		Q	m ³ /h										
	230 V	400 V	kW	HP		0	15	21	24	27	30	33	36	39	44	50
	A	A			l/min	0	250	350	400	450	500	550	600	650	733	833
MXH 3201	9,15	5,3	2,2	3	H m	18,4	16,3	15,3	14,8	14	13	12	10,8	9,3	6	-
MXH 3202		9,6	4	5,5		37	33	31	30	28,5	27	25	23	20,5	15	7,5
MXH 3203		12	5,5	7,5		55,5	50	47	45,5	43	40,5	38	35	31	23	10
MXH 3204		16	7,5	10		74,5	67	63	61	59	56	53	49	44	34	16,5

	3 ~		P ₂		Q	m ³ /h										
	230 V	400 V	kW	HP		0	21	27	33	39	45	48	51	54	60	66
	A	A			l/min	0	350	450	550	650	750	800	850	900	1000	1100
MXH 4801	11,5	6,6	3	4	H m	20	18	17	16	14,5	12,5	11,5	10,5	9,5	7	-
MXH 4802		12	5,5	7,5		41	35,3	33	30,5	27,5	24,5	22,5	21	19	14	7,5
MXH 4803		16	7,5	10		60,5	53	50	46	42,5	38	35	32,5	29	22,5	16

P₂ Rated motor power output.

Test results with clean cold water, without gas content.

IA/IN = D.O.L. starting current / Rated current

Tolerances according to ISO 9906, annex A.

Characteristic curves $n = 2900$ rpm

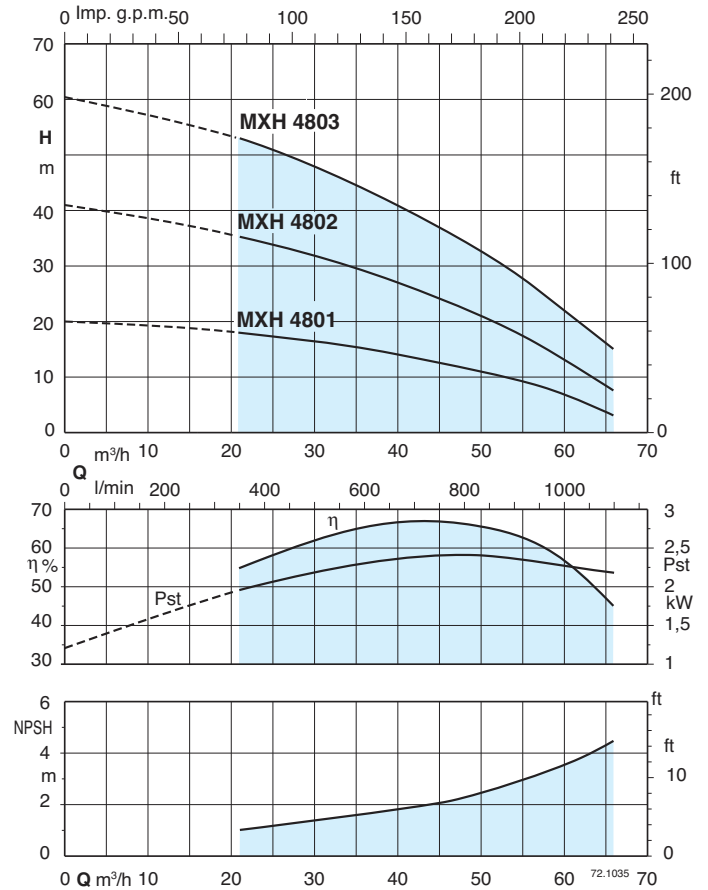
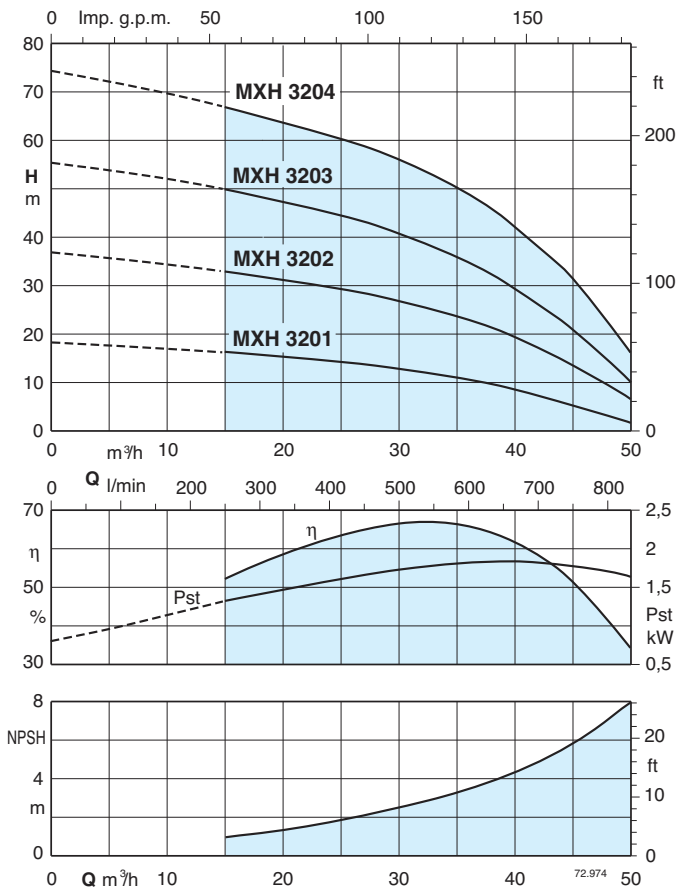

Designation

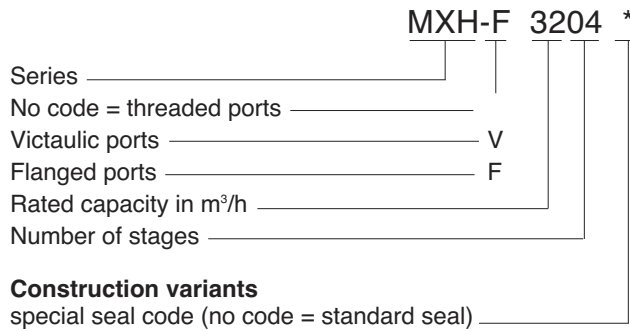

6.2

Dimensions and weights

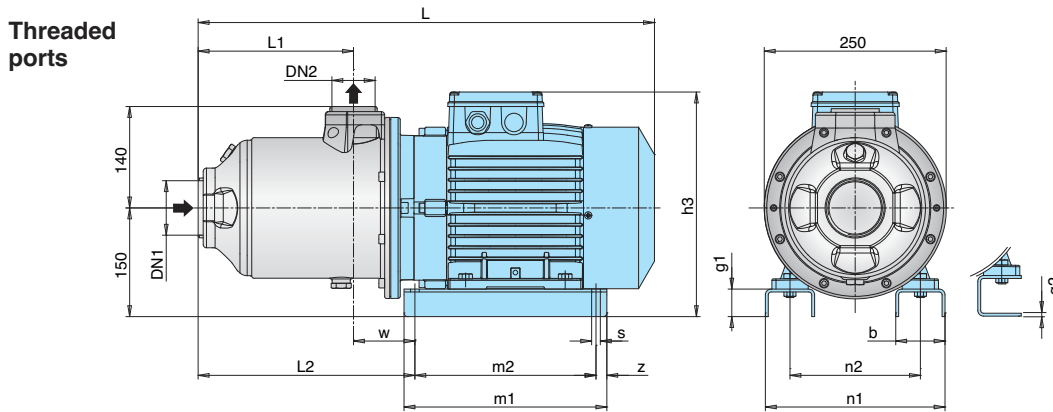

TYPE	DN1 ISO 228	DN2 ISO 228	mm														kg
			L	L1	L2	h3	m1	m2	n1	n2	z	b	s	w	g1	g2	
MXH 3201	G 2 1/2	G 2	461	120,5	216	280	205	175	170	130	15	54	10	92,5	-	6	26,5
MXH 3202	G 2 1/2	G 2	515	120,5	233	280	205	175	180	140	15	54	10	112	-	6	38
MXH 3203	G 2 1/2	G 2	582	166,5	251	310	280	250	258	190	15	68	12	84	38	-	49
MXH 3204	G 2 1/2	G 2	628	212,5	297	310	280	250	258	190	15	68	12	84	38	-	57
MXH 4801	G 3	G 2 1/2	545	136	263	280	205	175	180	140	15	54	10	128,5	-	6	35
MXH 4802	G 3	G 2 1/2	566	136	235	310	280	250	258	190	15	68	12	100	38	-	48,5
MXH 4803	G 3	G 2 1/2	628	197,5	297	310	280	250	258	190	15	68	12	100	38	-	57,5

Victaulic ports

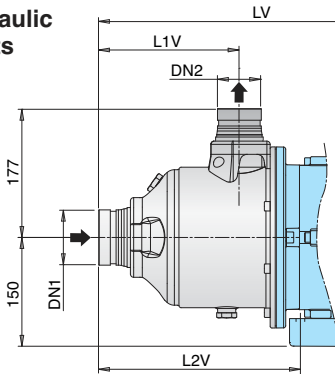

TYPE	DN1 mm	DN2 mm	mm		
			LV	L1V	L2V
MXH-V 3201	76,1 (DN65)	60,3 (DN50)	501	160	256
MXH-V 3202	76,1 (DN65)	60,3 (DN50)	555	160	273
MXH-V 3203	76,1 (DN65)	60,3 (DN50)	622	206	291
MXH-V 3204	76,1 (DN65)	60,3 (DN50)	668	252	337
MXH-V 4801	88,9 (DN80)	76,1 (DN65)	585	175	303
MXH-V 4802	88,9 (DN80)	76,1 (DN65)	606	175	275
MXH-V 4803	88,9 (DN80)	76,1 (DN65)	668	237	337

Flanged ports

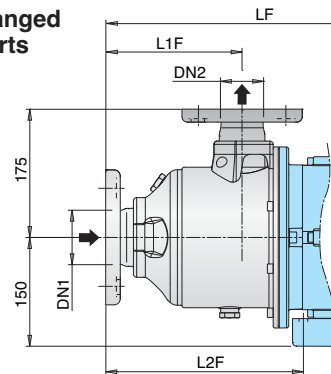

TYPE	DN1 mm	DN2 mm	mm		
			LF	L1F	L2F
MXH-F 3201	65	50	491	151	246
MXH-F 3202	65	50	545	151	263
MXH-F 3203	65	50	612	197	281
MXH-F 3204	65	50	658	243	327
MXH-F 4801	80	65	565	156	283
MXH-F 4802	80	65	586	156	255
MXH-F 4803	80	65	648	218	317

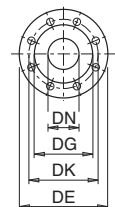

Flanges* EN 1092-2

DN	DE	DK	DG	Fori	
				N.	Ø
50	165	125	99	4	19
65	185	145	118	8	19
80	200	160	132	8	19

* ASME 150 lb (ex ANSI 150 lb)

Features

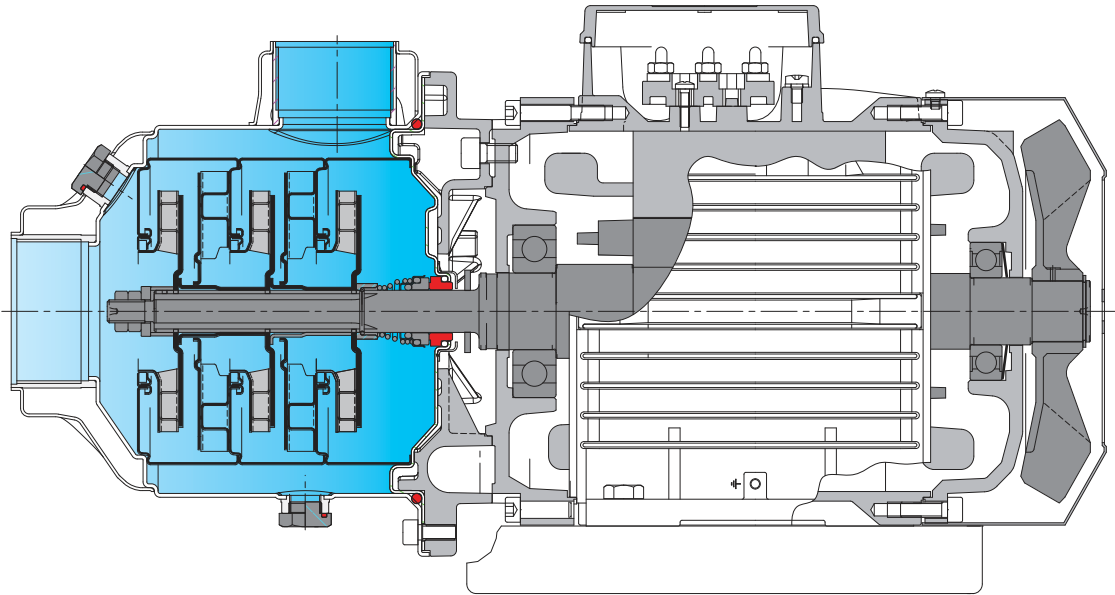

Flexibility

Three versions of ports: threaded, flanged and Victaulic.

Extra safety

With front axis suction port for optimum suction conditions.

Reliable

All hydraulic parts in contact with the pumped liquid are made in stainless steel.
For liquids from -15 °C to 110 °C.

Robust

Single-piece, thick barrel casing, open on one side only, with reinforced threaded ports.

Compact

The bracket between pump and motor is extremely compact.

Greater protection

Against leakage, with the pump casing cover separated from the motor shield.
Possibility of inspecting the seal through the side apertures between the two walls.