



Construction

Vertical multi-stage close coupled pumps with suction and delivery connections of the same diameter and arranged along the same axis (in-line).

All parts that come into contact with the liquid, including wet-end covers, are in chrome-nickel stainless steel with corrosion-resistant bearing sleeves lubricated by the pumped liquid.

Applications

For water supply systems.

For clean non-explosive liquids, without solid, filamentary or abrasive matter and non-aggressive for stainless steel (with adaptation of sealing materials on request).

A universal pump for civil and industrial use, for pressure-boosting systems, fire-extinguishing systems, high-pressure washing plants, irrigation, agricultural uses and sport installations.

Operating conditions

Temperature of liquid: from -15 °C to +90 °C.

Operating environment temperature: up to 40 °C.

Maximum permissible pressure in pump casing: 16 bar.

Motor

2-pole induction motor, 50 Hz ($n = 2900$ rpm).

MXV-B: three-phase 230/400 V $\pm 10\%$ up to 3 kW;
400/690 V $\pm 10\%$ from 3,7 to 7,5 kW.

MXV-BM: single-phase 230 V $\pm 10\%$,
with thermal protector.
Capacitor inside the terminal box.

Insulation class F.

Protection IP 54.

Constructed in accordance with: EN 60034-1;

EN 60335-1, EN 60335-2-41.

Special features on request

- Other voltages.
- Frequency 60 Hz.
- Protection IP 55.
- Special mechanical seal
- Pump casing seal rings in FPM.
- Higher or lower liquid or ambient temperatures.
- Flanges to screw, in chrome-nickel steel.

Materials (wetted parts)

Component	Material
External jacket	Chrome-nickel steel
Suction casing	
Delivery casing	
Stage casing	
Impeller	
Lower cover	
Upper cover	
Spacer sleeve	Chrome-nickel steel
Pump shaft	
Plug	1.4305 EN 10088 (AISI 303)
Mechanical seal ISO 3069 - KU	Ceramic alumina/Carbon/EPDM
Wear ring	PTFE
O-ring	NBR

Designation

Series MXV-B M 25-205

Single-phase motor (up to 2.2 kW) _____

DN ports in mm _____

Rated capacity in m³/h _____

Number of stages _____

Coverage chart $n \approx 2900$ rpm

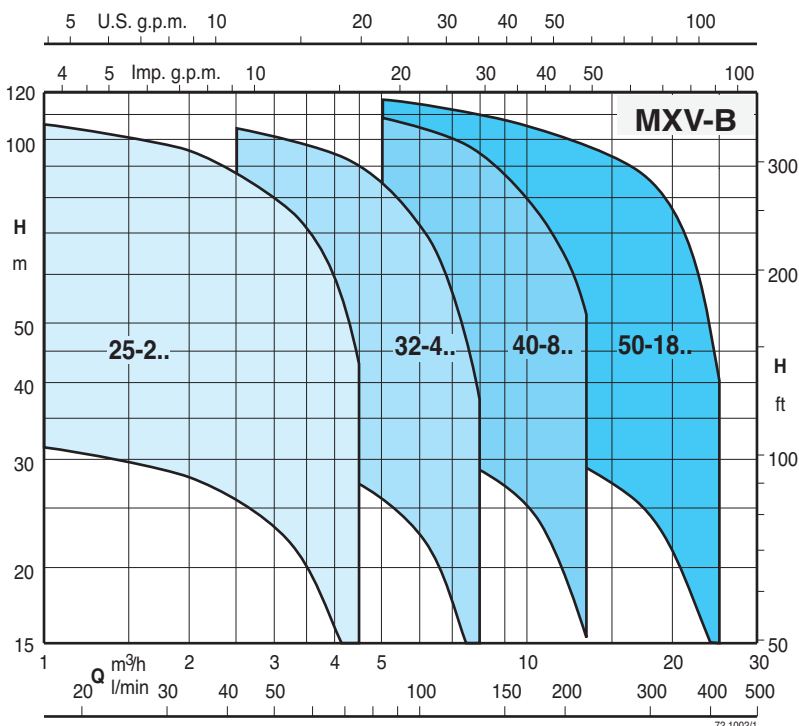

Characteristic curves and performance $n \approx 2900$ rpm

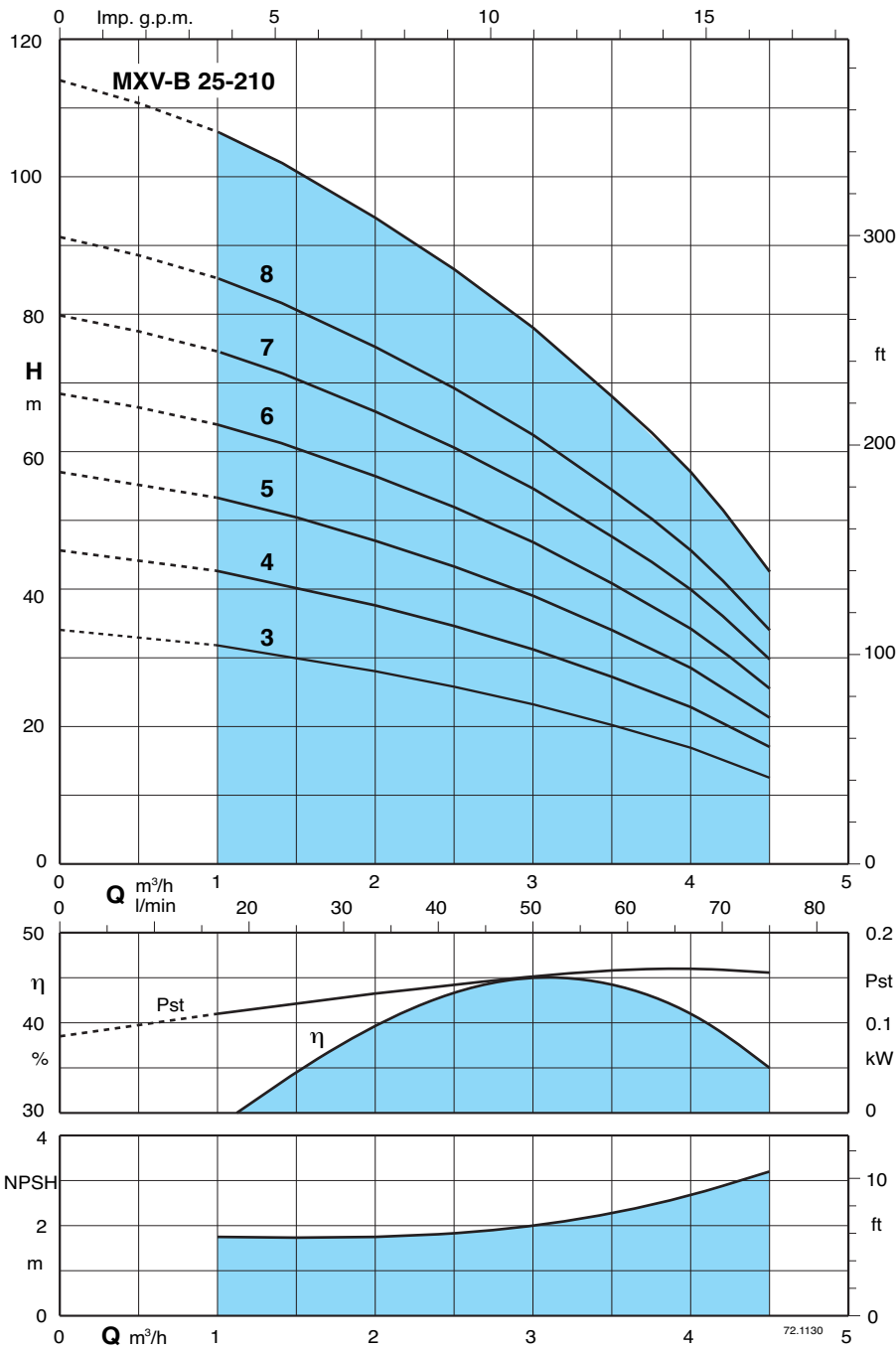

Test results with clean cold water, without gas content.
 A safety margin of + 0.5 m is recommended for the NPSH value.
 Tolerances in accordance with ISO 9906, Annex A.

Head and power values valid for liquids with density $\rho = 1,0 \text{ kg/dm}^3$ and kinematic viscosity $\nu = \text{max } 20 \text{ mm}^2/\text{sec}$.

Pst = Power with reference to one stage.
 P1 Max. power input.
 P2 Rated motor power output.

3 ~	230 V 400 V		1 ~	230 V		P2		m³/h Q l/min	H									
	A	A		A	A	kW	HP		0	1	1,5	2	2,5	3	3,5	4	4,5	
MXV-B 25-203	4	2,3	MXV-BM 25-203	5,8	0,75	1	H m	0	16,6	25	33,3	41,6	50	58,3	66,6	75		
MXV-B 25-204	4	2,3	MXV-BM 25-204	5,8	0,75	1		34	32	30	28	26	23,5	20,5	17	12,5		
MXV-B 25-205	4	2,3	MXV-BM 25-205	5,8	0,75	1		44	42,5	40	37,5	34,5	31	27	22,5	17		
MXV-B 25-206	5	2,9	MXV-BM 25-206	7,4	1,1	1,5		56	53	50	47	43	39	34	28	21		
MXV-B 25-207	5	2,9	MXV-BM 25-207	7,4	1,1	1,5		68	63,5	60,5	56	51,5	46,5	40,5	34	25		
MXV-B 25-208	7,5	4,3	MXV-BM 25-208	9,2	1,5	2		79,5	74	70,5	65,5	60	54,5	47,5	39,5	30		
MXV-B 25-210	7,5	4,3	MXV-BM 25-210	9,2	1,5	2		91	85	80,5	75	69	62	54	45,5	34		
								114	106	101	94	86	78	68	57	42		

Characteristic curves and performance $n \approx 2900$ rpm

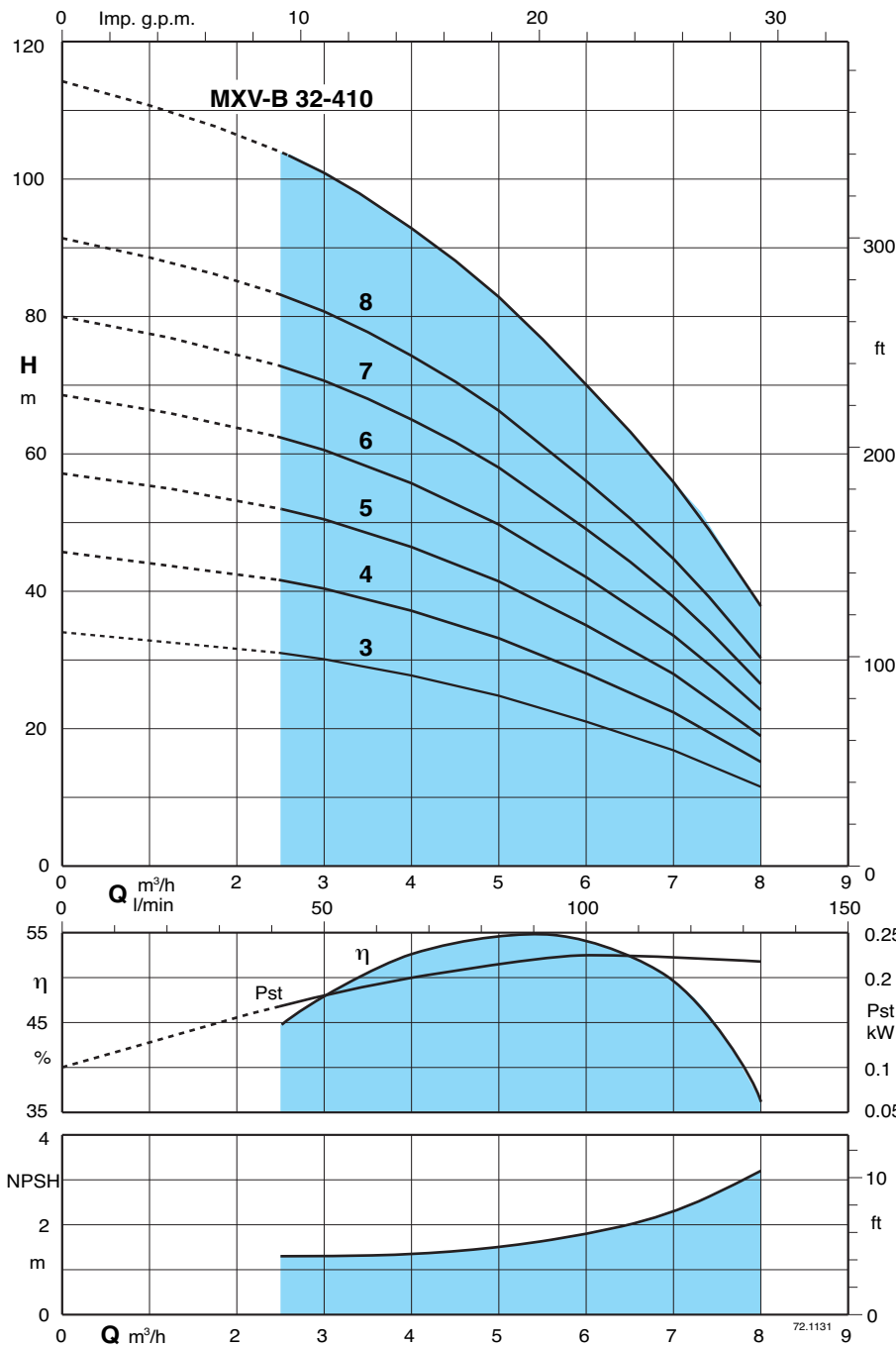

Test results with clean cold water, without gas content.
 A safety margin of + 0.5 m is recommended for the NPSH value.
 Tolerances in accordance with ISO 9906, Annex A.

Head and power values valid for liquids with density $\rho = 1,0 \text{ kg/dm}^3$ and kinematic viscosity $\nu = \text{max } 20 \text{ mm}^2/\text{sec}$.

Pst = Power with reference to one stage.
 P1 Max. power input.
 P2 Rated motor power output.

3 ~	230 V 400 V		1 ~	230 V		P ₂		m ³ /h Q l/min	H m									
	A	A		A	kW	HP	0		2,5	3	3,5	4	4,5	5	6	7	8	
MXV-B 32-403	4	2,3	MXV-BM 32-403	5,8	0,75	1	H m	0	41,6	50	58,3	66,6	75	83,3	100	116,6	133,3	
MXV-B 32-404	5	2,9	MXV-BM 32-404	7,4	1,1	1,5		34	31	30,5	29	28	26,5	25	21	17	11,5	
MXV-B 32-405	5	2,9	MXV-BM 32-405	7,4	1,1	1,5		45	41,5	40	38,5	36,5	34,5	32,5	27,5	22	14,5	
MXV-B 32-406	7,5	4,3	MXV-BM 32-406	9,2	1,5	2		56	51,5	50	48	46	43,5	41	34,5	27,5	18,5	
MXV-B 32-407	7,5	4,3	MXV-BM 32-407	9,2	1,5	2		68	62	60	58	55,5	52,5	49,5	42	33,5	22,5	
MXV-B 32-408	9,15	5,3			2,2	3		79,5	72,5	70,5	68	65	61,5	58	49	39	26,5	
MXV-B 32-410	9,15	5,3			2,2	3		91	83	80,5	78	74	70	66	56	44,5	30	
								114	104	101	97,5	93	88	83	70	56	38	

Characteristic curves and performance $n \approx 2900$ rpm

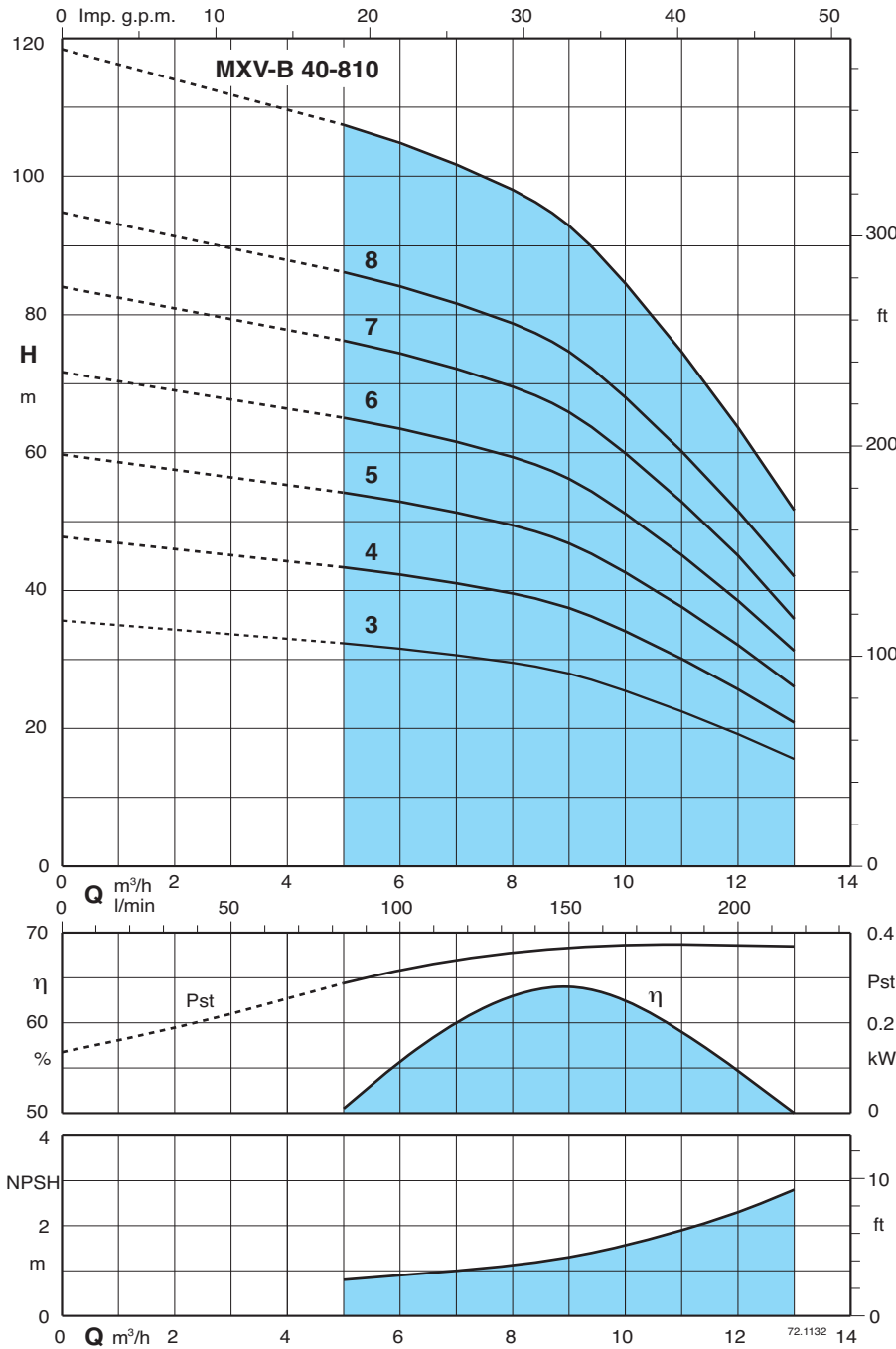

Test results with clean cold water, without gas content.
 A safety margin of + 0.5 m is recommended for the NPSH value.
 Tolerances in accordance with ISO 9906, Annex A.

Head and power values valid for liquids with density $\rho = 1,0 \text{ kg/dm}^3$ and kinematic viscosity $\nu = \text{max } 20 \text{ mm}^2/\text{sec}$.

Pst = Power with reference to one stage.
 P1 Max. power input.
 P2 Rated motor power output.

3 ~	230 V 400 V		1 ~	230 V		P2	m³/h Q l/min											
	A	A		A	kW			HP	0	5	6	7	8	9	10	11	12	13
MXV-B 40-803	5	2,9	MXV-BM 40-803	7,4	1,1	1,5	H m	35,5	32,5	31,5	31	29,5	28	25,5	22,5	19,5	15,5	
MXV-B 40-804	7,5	4,3	MXV-BM 40-804	9,2	1,5	2		47	43	42	41	40	37	34	30	26	21	
MXV-B 40-805	9,15	5,3			2,2	3		59	54	53	51	50	47	43	38	32	26	
MXV-B 40-806	9,15	5,3			2,2	3		71	65	63	62	59	56	51	45	39	31	
MXV-B 40-807	11,5	6,6			3	4		83	76	74	72	69	66	60	53	45	36	
MXV-B 40-808	11,5	6,6			3	4		95	87	85	82	79	75	69	60	51	42	
MXV-B 40-810		9,6			3,7	5		119	109	106	103	99	94	86	75	64	52	

Characteristic curves and performance $n \approx 2900$ rpm

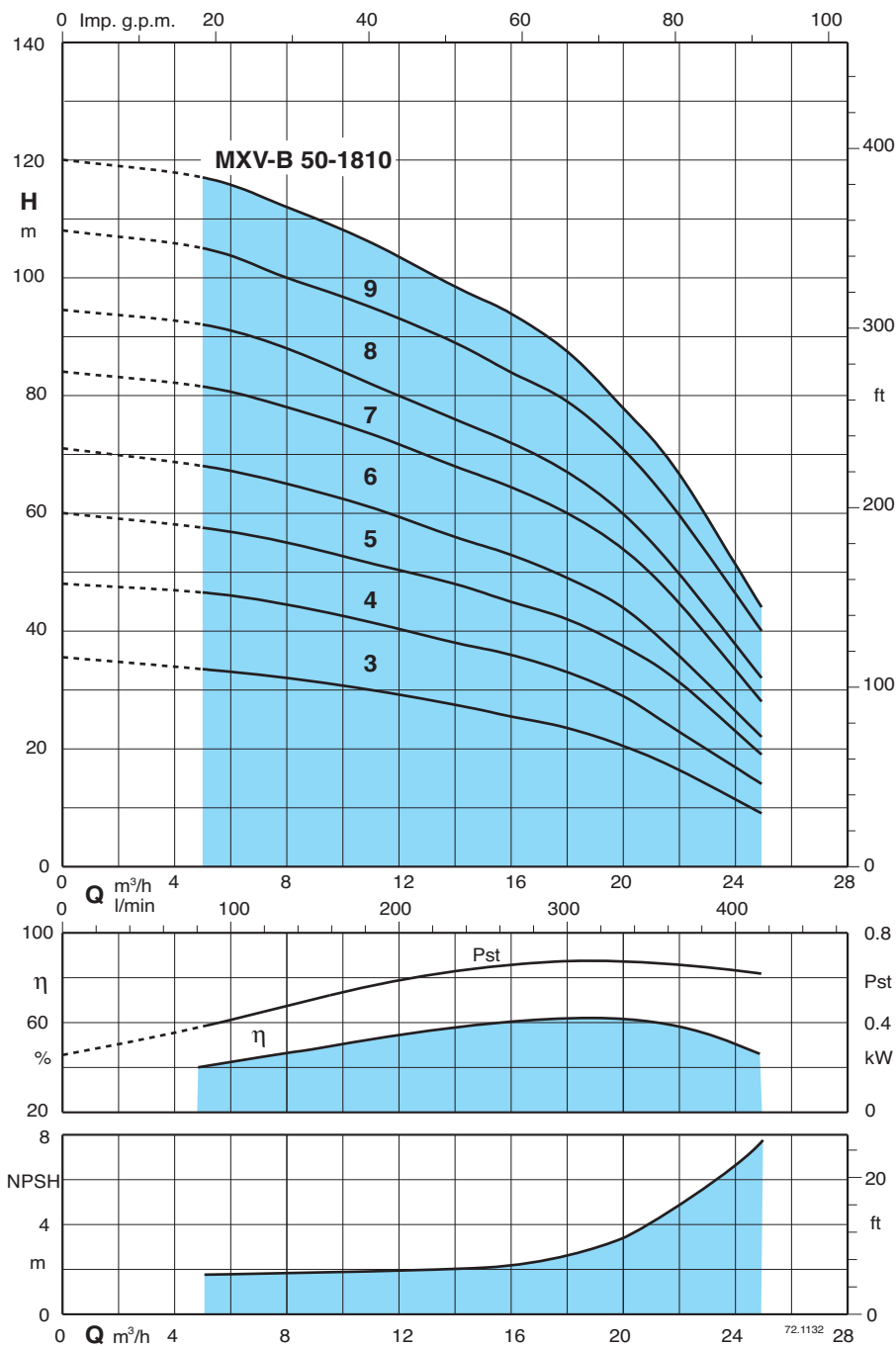

Test results with clean cold water, without gas content.

A safety margin of + 0.5 m is recommended for the NPSH value.

Tolerances in accordance with ISO 9906, Annex A.

Head and power values valid for liquids with density $\rho = 1,0 \text{ kg/dm}^3$ and kinematic viscosity $\nu = \text{max } 20 \text{ mm}^2/\text{sec}$.

Pst = Power with reference to one stage.

P1 Max. power input.

P2 Rated motor power output.

3 ~	230 V 400 V		P ₂		m ³ /h Q l/min	H m									
	A	A	kW	HP		0	5	8	11	14	16	18	20	22	25
MXV-B 50-1803	9,15	5,3	2,2	3	0	83,3	133,3	183,3	233	266	300	333	366	416	
MXV-B 50-1804	11,5	6,6	3	4	35,5	33,5	32	30	27,5	25,5	23,5	20,5	16,5	9	
MXV-B 50-1805		9,6	3,7	5	48	46,5	44,5	41,5	38	36	33	29	23	14	
MXV-B 50-1806		9,6	4	5,5	60	57,5	55	51,5	48	45	42	37,5	31,5	19	
MXV-B 50-1807		12	5,5	7,5	71	68	65	61	56	53	49	44	36	22	
MXV-B 50-1808		12	5,5	7,5	84	81,5	78	73,5	68	64,5	60	54	45	28	
MXV-B 50-1809		16	7,5	10	94,5	92	88	82	76	72	68	60	50	32	
MXV-B 50-1810		16	7,5	10	108	105	100	95	89	84	79	71	60	40	
					120	117	112	106	98	94	88	78	67	44	

Dimensions and weights

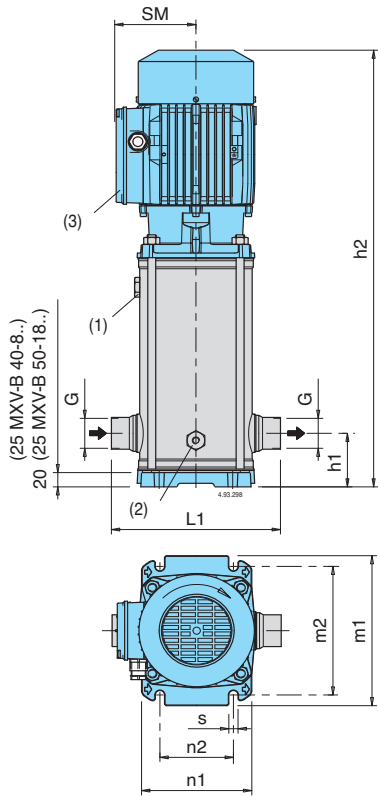

- (1) Filling
- (2) Draining
- (3) Standard position of terminal box
(for other positions rotate motor through 90° or 180°)

Pump	Motor P ₂		G		mm								Net weight	
	kW	HP	ISO 228	L1	h1	h2	SM	m1	m2	n1	n2	s	MXV-B kg	MXV-BM kg
MXV-B(M) 25-203	0,75	1	G 1	215	75	564	111	210	180	150	100	12,5	23	24
MXV-B(M) 25-204	0,75	1	G 1	215	75	565	111	210	180	150	100	12,5	23,5	24,5
MXV-B(M) 25-205	0,75	1	G 1	215	75	588	111	210	180	150	100	12,5	24,5	25,5
MXV-B(M) 25-206	1,1	1,5	G 1	215	75	612	111	210	180	150	100	12,5	26	27
MXV-B(M) 25-207	1,1	1,5	G 1	215	75	636	111	210	180	150	100	12,5	27	28
MXV-B(M) 25-208	1,5	2	G 1	215	75	660	111	210	180	150	100	12,5	30	31
MXV-B(M) 25-210	1,5	2	G 1	215	75	708	111	210	180	150	100	12,5	31	32
MXV-B(M) 32-403	0,75	1	G 1 1/4	215	75	564	111	210	180	150	100	12,5	24	25
MXV-B(M) 32-404	1,1	1,5	G 1 1/4	215	75	565	111	210	180	150	100	12,5	25	26
MXV-B(M) 32-405	1,1	1,5	G 1 1/4	215	75	588	111	210	180	150	100	12,5	26	27
MXV-B(M) 32-406	1,5	2	G 1 1/4	215	75	612	111	210	180	150	100	12,5	28	29
MXV-B(M) 32-407	1,5	2	G 1 1/4	215	75	636	111	210	180	150	100	12,5	29	30
MXV-B 32-408	2,2	3	G 1 1/4	215	75	660	111	210	180	150	100	12,5	31	-
MXV-B 32-410	2,2	3	G 1 1/4	215	75	708	111	210	180	150	100	12,5	32	-
MXV-B(M) 40-803	1,1	1,5	G 1 1/2	225	80	593	111	246	215	190	130	14	27	28
MXV-B(M) 40-804	1,5	2	G 1 1/2	225	80	593	111	246	215	190	130	14	28	29
MXV-B 40-805	2,2	3	G 1 1/2	225	80	623	111	246	215	190	130	14	30	-
MXV-B 40-806	2,2	3	G 1 1/2	225	80	653	111	246	215	190	130	14	31	-
MXV-B 40-807	3	4	G 1 1/2	225	80	746	128	246	215	190	130	14	42	-
MXV-B 40-808	3	4	G 1 1/2	225	80	776	128	246	215	190	130	14	46	-
MXV-B 40-810	3,7	5	G 1 1/2	225	80	953	128	246	215	190	130	14	48	-
MXV-B 50-1803	2,2	3	G 2	250	90	595	130	246	215	190	130	14	31	-
MXV-B 50-1804	3	4	G 2	250	90	701	128	246	215	190	130	14	41	-
MXV-B 50-1805	3,7	5	G 2	250	90	738	128	246	215	190	130	14	46	-
MXV-B 50-1806	4	5,5	G 2	250	90	776	128	246	215	190	130	14	47	-
MXV-B 50-1807	5,5	7,5	G 2	250	90	841	160	246	215	190	130	14	58	-
MXV-B 50-1808	5,5	7,5	G 2	250	90	878	160	246	215	190	130	14	59	-
MXV-B 50-1809	7,5	10	G 2	250	90	916	160	246	215	190	130	14	66,5	-
MXV-B 50-1810	7,5	10	G 2	250	90	953	160	246	215	190	130	14	67,5	-

Features

Wider Range of Application

All parts that come into contact with the liquid, including wet-end covers, are in chrome-nickel stainless steel.
With corrosion-resistant seal rings and guide ring.

Low Cost Installation

Vertical construction with reduced pump height for installation in small spaces.
In-line connections to simplify the piping layout with the possibility of inserting the pump in straight pipe-lines.
Disassembly, inspection or cleaning of internal parts without removal of piping.

Robust and Reliable

The suction and discharge nozzles arranged in-line absorb the forces of the piping on the pump without the creation of distorting loads causing local friction and early wears.
The lantern brackets compact and robust design maintains a sure alignment between rotating and fixed parts, reducing vibration.
The upper cover design prevents entrapment of air around the mechanical seal.

Low-Noise Operation

The water filled shroud around the stages and thick external walls, work together for low-noise operation.

