



Construction

Self-priming swimming pool pumps with built-in strainer and motor insulated from pumped water. The pump is made with high quality plastic materials, corrosion and sand erosion resistant. With stainless steel diffuser. Base-plate kit.

Applications

- For water circulation in swimming pool filtration systems.
- For clean or slightly dirty water with solids in suspension.

Operating conditions

Water temperature up to 60 °C.
Ambient temperature up to 40 °C.
Maximum permissible pressure in the pump casing 2,5 bar.
Continuous duty.

Motor

2-pole induction motor, 50 Hz (n = 2800 rpm).

MPC: three-phase 230/400 V ± 10%.

MPCM: single-phase 230 V ± 10%, with thermal protector. Capacitor inside the terminal box.

Insulation class F.

Protection IP X4.

Classification scheme IE2 for three-phase motors from 0,75 kW.

Constructed in accordance with: EN 60034-1; EN 60034-30. EN 60335-1, EN 60335-2-41.

Special features on request

- Other voltages.
- Frequency 60 Hz (as per 60 Hz data sheet).

Patents: EP 0 460 597
US 5 226 790

Certification marks for MPCM, up to 1,5 kW:



Materiali

Component	Material
Pump casing	Glass reinforced
Diffuser cover	thermoplastic
Impeller	PPO-GF30, NORYL
Strainer cover	Transparent polycarbonate, LEXAN
Strainer basket	Polypropylene
Diffuser funnel and wear-ring	Cr-Ni-Mo steel AISI 316
Mechanical seal	Ceramic alumina, Carbon, FPM

Coverage chart n ≈ 2800 rpm

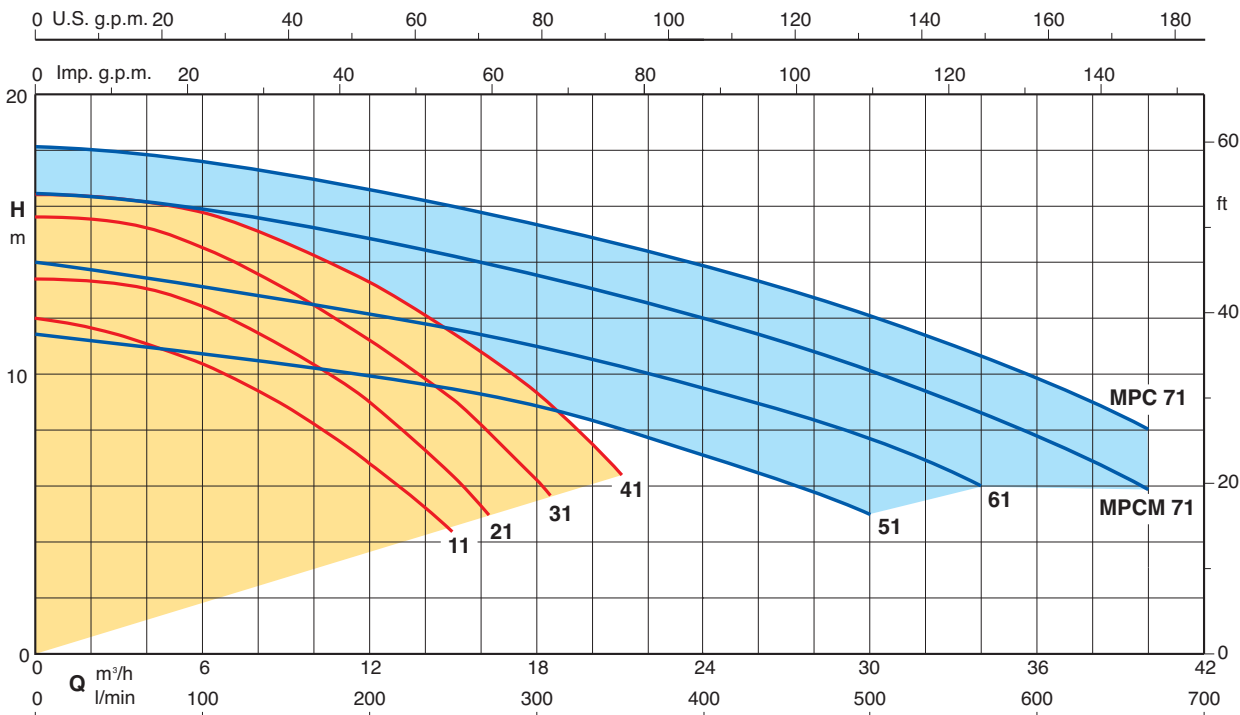

Performance $n \approx 2800$ rpm

	3~ 230 V 400 V		1~ 230 V P ₁		P ₂		Q m ³ /h l/min	H m	0	3	6	9	12	15	18	21
	A	A	A	kW	kW	HP			0	50	100	150	200	250	300	350
MPC 11	2,8	1,6	MPCM 11	3,3	0,73	0,37	0,5	11,9	11,4	10,3	8,9	6,8	4,2			
MPC 21/A	3	1,7	MPCM 21/A	4,5	1	0,55	0,75	13,4	13,3	12,4	10,9	9	6,3			
MPC 31/A	3,7	2,2	MPCM 31/A	5,4	1,2	0,75	1	15,6	15,5	14,5	13	11,2	9,1	6,2		
MPC 41	4,7	2,7	MPCM 41	7	1,6	1,1	1,5	16,4	16,2	15,8	14,7	13,3	11,4	9,3	6,4	

	3~ 230 V 400 V		1~ 230 V P ₁		P ₂		Q m ³ /h l/min	H m	0	3	9	15	18	21	24	27	30	34	40
	A	A	A	kW	kW	HP			0	50	150	250	300	350	400	450	500	567	667
MPC 51	4,7	2,7	MPCM 51	7	1,6	1,1	1,5	11,5	11	10,5	9,5	9	8	7	6	5			
MPC 61	6,2	3,6	MPCM 61	9,2	2	1,5	2	14	13,5	12,5	11,5	11	10,5	9,5	8,5	7,5	6		
			MPCM 71/A	11,2	2,5	1,8	2,5	16,4	15,9	14,9	14	13,4	12,7	12,1	11,3	10,2	8,5	5,8	
MPC 71/A	9,15	5,3				2,2	3	18,2	18	17	16	15,5	14,5	14	13	12	10,5	8	

P₁ Max. power input.

P₂ Rated motor power output.

H Total head in m.

Tolerances according to ISO 9906, annex A.

Self-Priming Capability with the pump located above the water level

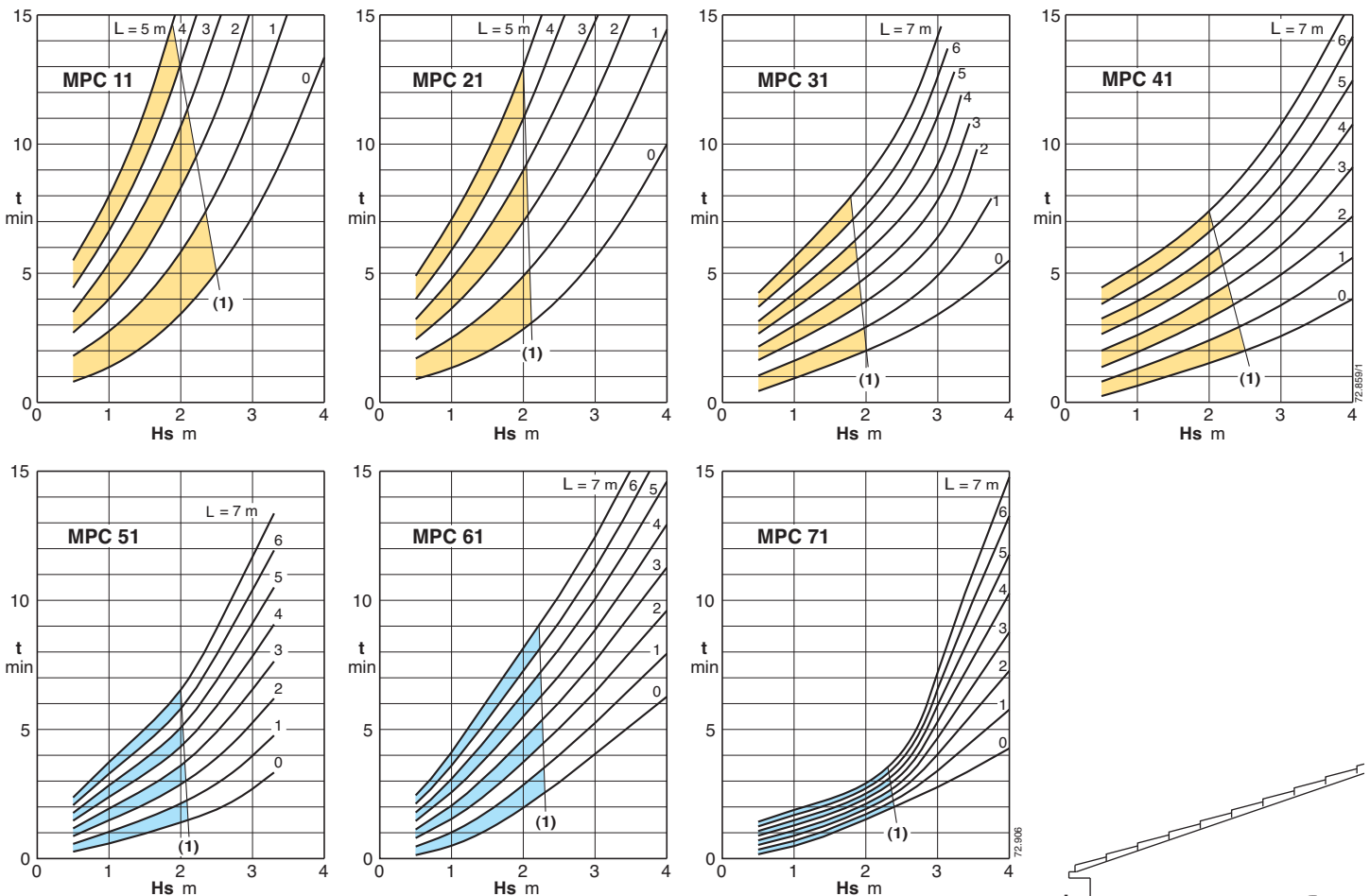

(1) Application limit for automatic self-repriming at each start-up, without check valve.

L (m) Horizontal length of suction pipe above the water level.

H_s (m) Suction lift.

t (min) Self-priming time.

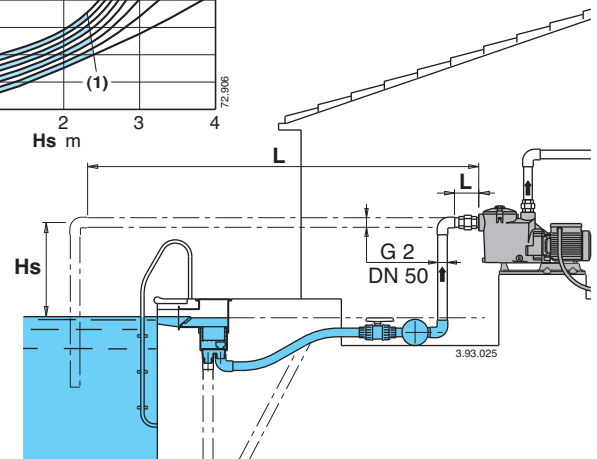

Dimensions and weights

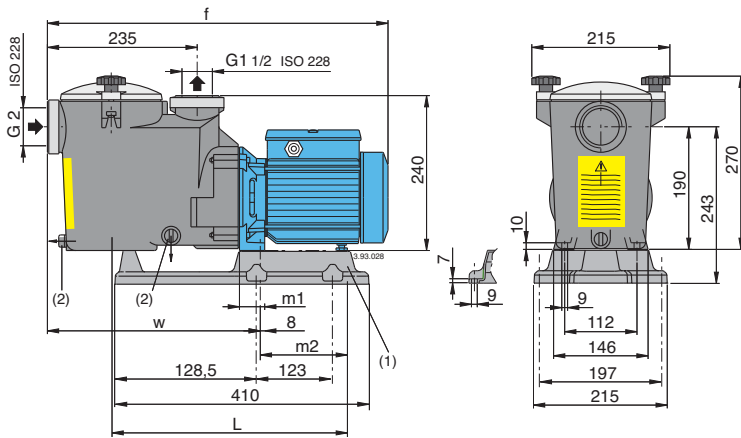

TYPE	mm					kg	
	f	L	m1	m2	w	MPC	MPCM
MPC 11 - MPCM 11	504	354	34	122	332	8,9	9
MPC 21/A - MPCM 21/A	536	373	39	136	337	10,2	11,3
MPC 31/A - MPCM 31/A	536	373	39	136	337	11,2	12,2

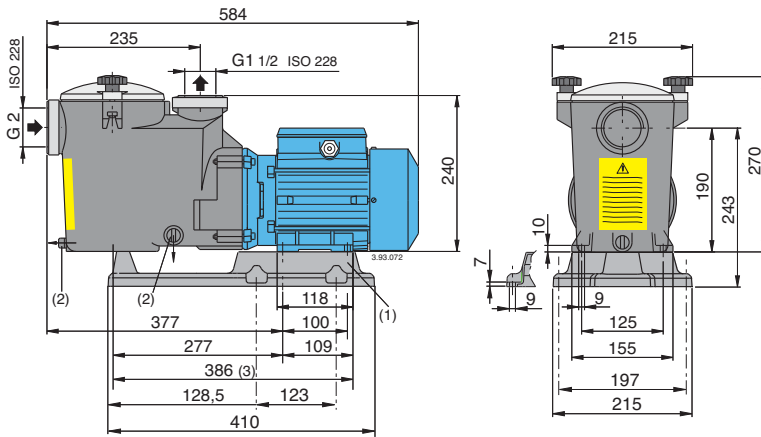

MPCM 41 17,5 kg
MPC 41 16,0 kg

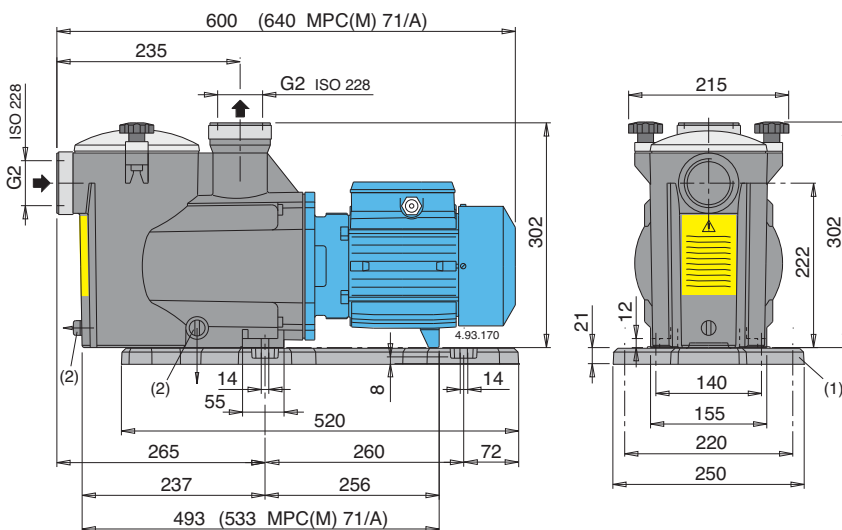

MPCM 51 18,9 kg
MPC 51 17,4 kg
MPCM 61 20,7 kg
MPC 61 19,6 kg
MPCM 71/A 23,8 kg
MPC 71/A 22,5 kg

(1) Base-plate kit

(2) Draining

Features

